

1. Purpose

This document is provided as an installation and operational reference for the GoDigital Configur8r™ System Design Software. It is a file used with Microsoft Excel 5.0.

2. Revision

This Revision G adds terminology for the XCel-8 CarrierNode. Revision F added Configur8rs for XCel-4a Systems.

2.1 Specific Configur8rs available on floppy disk:

Part #	System Type	Line Power	Loop/Drop Testing Option	Application Type
XCel-8 with XCel Multi-Service 19-inch and 23-inch Shelves and with XCel-8 CarrierNode				
990229	XCel-8	± 190 Vdc	Loop Test w/ 4Tel Signatures	Multi-Svc Shelves, Loc. Pwr. Rptrs for 8 POTS
990231	XCel-8	± 190 Vdc	Loop Test & Mechanized Drop Test (MDT) w/ MLT Signatures	Multi-Svc Shelves, Single Loop for 8 POTS
990259	XCel-8	± 130 Vdc	Loop Test & Mechanized Drop Test (MDT) w/ MLT Signatures	Multi-Svc Shelves, Loc. Pwr. Rptrs for 8 POTS
XCel-12 with V.90 Modem Support and XCel Multi-Service 19-inch and 23-inch Shelves				
990223	XCel-12	± 190 Vdc	Loop Test w/ 4Tel Signatures	Multi-Svc Shelves, Loc. Pwr. Rptrs for 12 POTS
990230	XCel-12	± 190 Vdc	Loop Test & Mechanized Drop Test (MDT) w/ MLT Signatures	Multi-Svc Shelves, Single Loop for 12 POTS
990244	XCel-12	± 130 Vdc	Loop Test & Mechanized Drop Test (MDT) w/ MLT Signatures	Multi-Svc Shelves, Loc. Pwr. Rptrs for 12 POTS
XCel-4a XCel Multi-Service 19-inch and 23-inch Shelves				
990347	XCel-4a	± 190 Vdc and/or ± 130 Vdc	Not Applicable with the XCel-4a	Multi-Svc Shelves, Line Power, 4 ADSL Lines
GDSL-3i with GDSL STANDARD 19-inch and 23-inch Shelves				
990219	GDSL-3i	± 130 Vdc	N/A	Standard Shelves, Single Loop for IDSL/ISDN
GDSL-8 with GDSL STANDARD 19-inch and 23-inch Shelves				
990220	GDSL-8 & GDSL-8 V.90	± 190 Vdc	Loop Test w/ 4Tel Signatures	Standard Shelves, Loc. Pwr. Rptrs for 8 POTS
990221	GDSL-8	± 190 Vdc	Loop Test w/ 4Tel Signatures	Standard Shelves, Single Loop for 8 POTS
990222	GDSL-8	± 130 Vdc	Loop Test w/ MLT Signatures	Standard Shelves, Loc. Pwr. Rptrs for 8 POTS

3. Overview

NOTE: This Configur8r READ ME supports all current XCel and GDSL equipment options that are available from GoDigital. Individual telephone companies may have certain equipment items that have been “approved” by their standardization organizations, and other equipment items on this version of the Configur8r may not be approved by that particular organization. If a planner or engineer is uncertain of which products are approved, they should check with their standardization office or alternatively with GoDigital Sales.

- 3.1** XCel and GDSL systems support multi-line POTS, ADSL, or IDSL/ISDN services over long loop access distances, in some cases beyond 125,000 feet. The systems are comprised of a shelf, plug-in card or cards, repeaters, drop repeaters and remote terminals that can be configured in many ways as limited by available line powering. The Configur8r lets you enter in the length and gauge of the various cable spans, enter the type of element desired at each span termination, and enter the number of drops from each element. The Configur8r then calculates a “worst case” (for POTS three lines ringing and the rest off hook) power consumption for each span and for the total system, and indicates if the configuration is within system specifications and will operate reliably.
- 3.2** The Configur8r is available on diskette from GoDigital. The Configur8r software can be loaded on a local server for use, on a desktop or a laptop computer.

Installation Note

Configur8r™ READ ME System Design Software

3.3 Configur8r Installation Information

- Make certain you are using the appropriate version of the Configur8r.
- Save the selected file at a convenient location on your computer hard drive or server.
- Open your application software, Excel 5.0 or later.
- Go to 'File', 'Open' and select the appropriate Configur8r file.
- When the Configur8r opens, type in the name of your loop at the top and follow the stepwise instructions. A sample is shown at the end of this document.

3.4 Structure of the Configur8r Software

- The Configur8r consists of either one or three separate Worksheets.
- Each Worksheet is used to design a powered SECTION.
- Worksheet # 1 will be used by itself for most loops and is based on line powering from the CTU. Some customers prefer not to use locally powered repeaters and separate Configur8rs are available for C.O. line powered applications only (with only one Worksheet).
- Worksheets #2 and #3 are used only when Locally Powered Repeaters are needed to extend the range of the XCel or GDSL system.

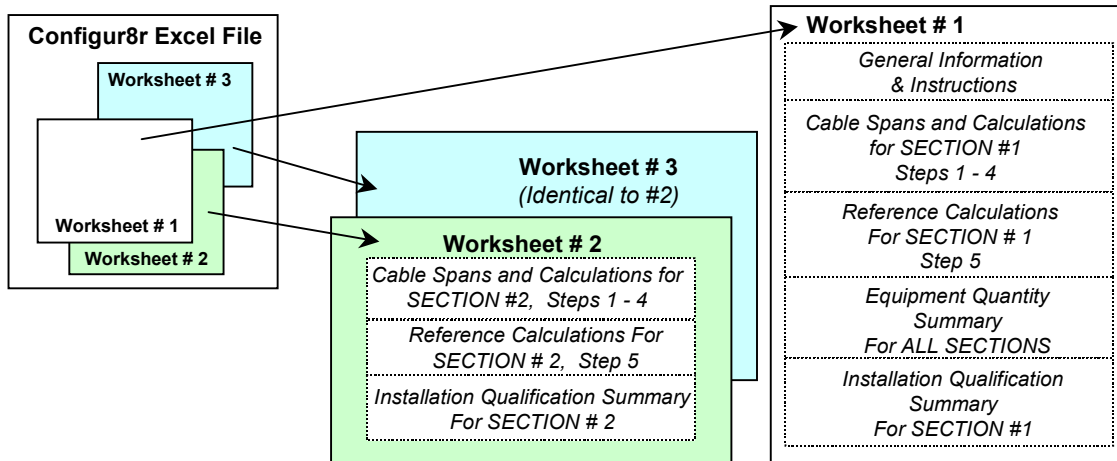

3.5 How the Configur8r Works

- 3.5.1 Basic Configur8r:** The Configur8r enables a XCel or GDSL system to be engineered properly based on the overall signal loss (dB) and resistance (ohms), from the CTU to the last unit in a XCel or GDSL system and to the subscriber over standard drop pairs.

A basic C.O. line powered system uses only Worksheet #1. Calculations are based on:

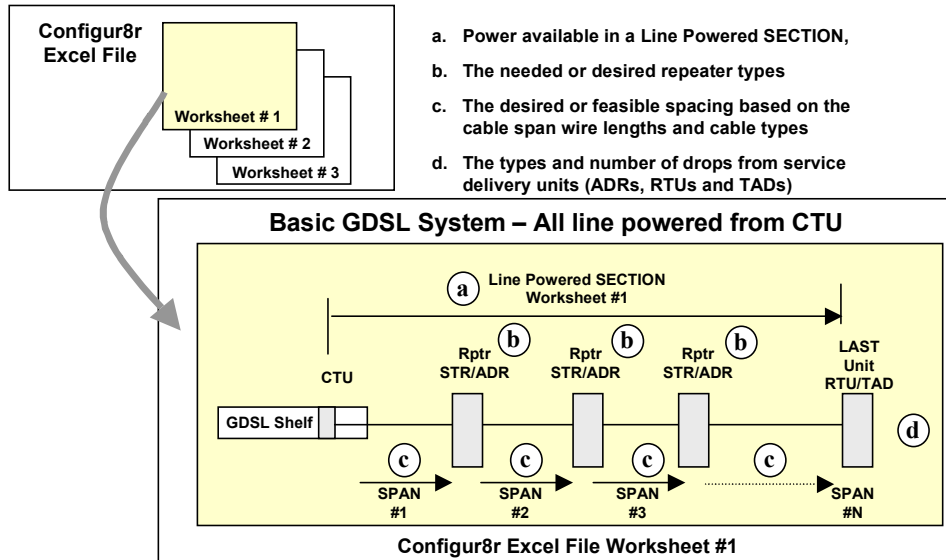

3.5.2 Configur8r supporting Locally Powered XCel or GDSL Repeaters: The Configur8r uses separate worksheets for each powered SECTION, beginning with the powering CTU. The second and third SECTIONS begin with a Locally Powered Repeater (STR LP).

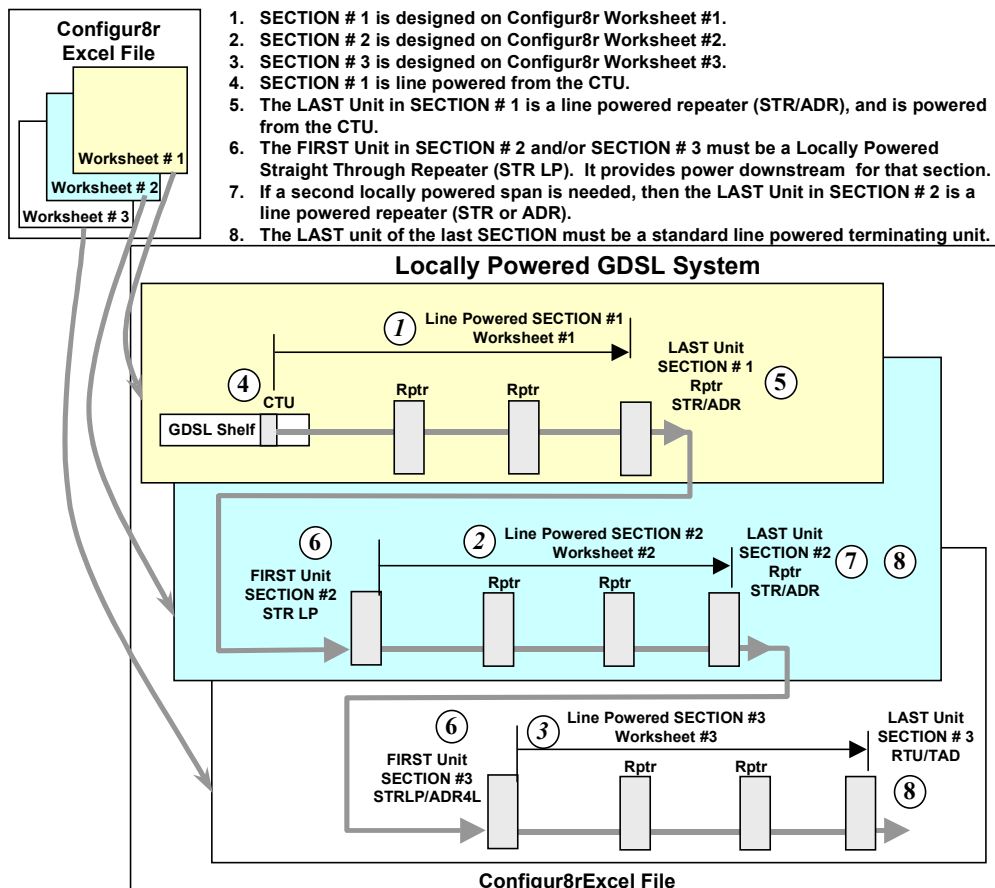

Installation Note

Configur8r™ READ ME System Design Software



4. **Instructions for Page 1 of each Configur8r Section/Worksheet**
- Make sure that you have the most recent revision by checking with your company or GoDigital, and that it is for the correct DSL voltage level and System type.
 - Each locally powered portion of the loop is configured on a separate worksheet in this Configur8r. The FIRST element of worksheet 2 and worksheet 3 are reserved for locally powered units only (STRLP).
 - The top of each worksheet (1, 2 & 3) has blank spaces for naming the loop and for identifying the OSP cable pair, the Exchange name or identifier, and a Work Order reference number.
 - For the first section use Sheet 1, and begin with Step 1.
 - The Configur8r versions for the different XCel and GDSDL Systems may have fewer or more than the Steps below, and they may be numbered differently from this example listing, but the sequence will generally be the same.
- 4.1 **Step 1:** The “default” setting for distance measurements is feet. If you would like to enter your span lengths in meters enter an “M” into the cell provided. The Configur8r will automatically adjust the labeling and the maximum reach values to “meters” on all worksheets.
- 4.2 **Step 2:** The LAST UNIT for a powered section is entered into the last column on each worksheet. Entering the LAST unit on a section worksheet activates the power calculation software for that section.
- When no local power is planned, the LAST UNIT will always go in the last column of Worksheet 1.
 - When one local power unit is planned, the LAST UNIT on Worksheet 1 will be the unit placed in front of the first local power unit.
 - When two local power units are planned, the LAST UNIT on Worksheet 2 will be the unit placed in front of the second local power unit.
- 4.3 **Step 3:** Verify that the “initial current” value is set at the designated value (0.083, 0.094, or 0.115). This value appears in a box at approximately the middle of the spreadsheet.
- When a new Configur8r is shipped this value is preset at the appropriate initial current, so no change should be necessary.
 - The value may have been changed the last time the Configur8r was used, as part of the process to check the idle state current and voltage (see step 5).
- Note: the **XCel-4a Configur8r** will at this point ask a series of questions to accommodate Spectrum Management capabilities. The questions asked are:

 - Is CO deployed ADSL in the same Binder Group or is it planned?
 - Does the Telco have guaranteed or standardized CO-based downstream ADSL speeds and ADSL deployment reach?
 - Enter Guaranteed (minimum) CO-based ADSL downstream Speed.
 - Enter Maximum CO-based ADSL Reach (mixed gauge OK).

Based on the above user inputs, the Configur8r will guard against placing XCel-4a units in loop locations that could contribute to interference with CO-based ADSL service levels. Additional information on Spectrum Management procedures is provided in TECH NOTE 010108, available separately from GoDigital.
- 4.4 **Step 4:** For each span Enter the Unit, Drop and Cable information. Both the number of drops and their location affect the total system reach.
- For each span, enter the first letter of the various elements you select, e.g. “S” for an STR repeater.
 - Enter the number of subscriber drops from each element up to the maximum system total:
 - XCel-8 or GDSDL-8: Eight (8) maximum in loop
 - XCel-12: Twelve (12) maximum in loop
 - XCel-4a: Four (4) maximum in loop
 - GDSDL-3i: Three maximum in loop

4.4.1 Drop Reach Planning

Table 4.4.1-1

XCel /GDSL POTS STANDARD Drop Reach

STANDARD Drop Reach for POTS (XCel-8 / XCel-12)			
26 Ga.	Drop Reach	1,400 ft	420 m
	Calculated Res.	130 Ohms	
24 Ga.	Drop Reach	2,230 ft	670 m
	Calculated Res.	130 Ohms	
22 Ga.	Drop Reach	3,550 ft	1,080 m
	Calculated Res.	130 Ohms	
19 Ga.	Drop Reach	7,110 ft	2,160 m
	Calculated Res.	130 Ohms	
Limited by power to 130 Ohms			

Note: Standard Reach POTS Drop Limits

Table 4.4.1-1, STANDARD drops support resistance of 560 ohms. This includes 430 ohms for the CPE leaving 130 ohms for the drop pair.

Table 4.4.1-2

Basic EXTended Reach POTS Drop Reach

EXTENDED Drop Reach for POTS (XCel-8 ONLY)			
EXT "SHORT" Drop Reach for POTS			
26 Ga.	Drop Reach	2,910 ft	880 m
	Calculated Res.	270 Ohms	
24 Ga.	Drop Reach	4,630 ft	1,410 m
	Calculated Res.	270 Ohms	
22 Ga.	Drop Reach	7,370 ft	2,240 m
	Calculated Res.	270 Ohms	
19 Ga.	Drop Reach	14,780 ft	4,500 m
	Calculated Res.	270 Ohms	
EXT "LONG" Drop Reach for POTS*			
26 Ga.	Drop Reach	6,800 max*	2,070 m
	Calculated Res.	630 Ohms	
24 Ga.	Drop Reach	9,140 max*	2,780 m
	Calculated Res.	532 Ohms	
22 Ga.	Drop Reach	11,610 max*	3,530 m
	Calculated Res.	425 Ohms	
19 Ga.	Drop Reach	16,720 max*	5,090 m
	Calculated Res.	305 Ohms	
<p>* EXTended Reach LONG is limited by signal loss of 4.0 dB for the drop (not by drop resistance). Per TR-057, limit is 8 dB @ 1 kHz from switch to premises and 4.0 dB occurs in XCel-8 loop.</p>			

Note: Basic EXTended Reach POTS Drop Limits

Table 4.4.1-2 specifies the Maximum Recommended EXTended reach limits for LONG and SHORT in accordance with signal loss, per TR-057. Maximum resistance values are estimates and actual resistance and reach will vary based on condition of cables. 4.0 dB of the allowable signal loss is reserved for the XCel or GDSL transport and equipment and the remaining 4.0 dB are available for the drop.

Table 4.4.1-3

Alternative EXT Reach XCel/GDSL POTS Drop Reach

EXTENDED Reach Drops 8.5 dB Signal Loss		EXT Reach SHORT	EXT Reach LONG*
26 Ga.	Drop Reach	2,910 ft	6,800 ft
	Calculated Res.	270 ohms	630 Ohms
24 Ga.	Drop Reach	4,630 ft	10,137 ft
	Calculated Res.	270 ohms	599 Ohms
22 Ga.	Drop Reach	7,370 ft	12,857 ft
	Calculated Res.	270 ohms	478 Ohms
19 Ga.	Drop Reach	14,780 ft	18,592 ft
	Calculated Res.	270 ohms	344 Ohms
<p>* EXTended Reach LONG is limited by signal loss of 4.0 dB for the drop (not by drop resistance). Per some PUC/Telco specs., limit is 8.5 dB @ 1 kHz from switch to premises and 4.5 dB in XCel-8 loop.</p>			

Note: Alternative EXT Reach POTS Drop Limits

Table 4.4.1-3 provides an alternative EXTended reach limits for LONG and SHORT drops based on some PUC/Telco Standard practices. This Standard supports drops with signal loss up to 8.5 dBm, adding reach to very difficult subscriber locations. 4.0 dB of the allowable signal loss is reserved for the XCel or GDSL transport and equipment and the remaining 4.5 dB are available for the drop.

Table 4.4.1-4

XCel-4a ADSL Drop Reach

XCel-4a ADSL Drop Reach (feet and meters)			
26 Ga.	Drop Reach	8,500 ft	2,950 m
	Calculated Res.	789 Ohms	
24 Ga.	Drop Reach	11,000 ft	3,350 m
	Calculated Res.	641 Ohms	
22 Ga.	Drop Reach	14,000 ft	4,260 m
	Calculated Res.	513 Ohms	
19 Ga.	Drop Reach	20,000 ft	6,090 m
	Calculated Res.	366 Ohms	
@ 1.5 Mbps Downstream and 6 dB SNR			

Note: XCel-4a ADSL Drop Limits

Table 4.4.1-4 provides and drop reach limits for the XCel-4a Systems ADSL lines. These ADSL lines do not require the delivery of voltage to power CPE and are therefore limited only the signal loss.

Installation Note

Configur8r™ READ ME System Design Software



4.4.1.1 POTS System Drop Reach

Most XCel and GDSL Systems use “STANDARD” POTS drop reach units. If the unit entered is equipped to support EXTENDED reach drops, the Configur8r will request that you identify how many drops are “LONG”. This is the worst case for power management. By designating some or all drops as “SHORT” on a system, power can be conserved for greater DSL Reach. See following tables. Power adjustments to the XCel or GDSL-8 Configur8r System Design software tool are required as a result of the increased power load in the RTU 8P EXT for longer drops. The Configur8r automatically makes these adjustments and will assume that all drops are at maximum range unless otherwise noted. Signal loss limitations with the longer RTU 8P EXT drops must be considered when planning for unit placement. These limitations were not applicable with the standard RTU8 because the overall limitation was always drop resistance (130 ohms) and associated powering. See the following tables.

4.4.2 Enter the wire span length in the respective location for cable gauge/type. Multiple cable gauge/types can be entered into a single column to define a span.

- Only PIC cable is directly supported in the Configur8r.
- If you have pulp cable please refer to the below tables and to Section 10.0 below.
- When engineering POTS Systems, the Configur8r program automatically assumes a worst case scenario with the furthest three lines ringing, and the remainder of the lines on the loop in an off-hook state.

NOTE: The Configur8r automatically assigns 200 feet of 24 ga cable to the loop prior to the first span. This is to accommodate the office wiring of the DSL to the MDF. Loss and Resistance for this 200 feet are included in measurements for the first span.

Table 4.4.2-1: XCel/GDSL8, & GDSL-3i Span Reach

XCel-8 SPAN Reach (feet and meters)				
Feet	19 AWG	22 AWG	24 AWG	26 AWG
PIC - UG	30,550 ft	20,810 ft	15,330 ft	10,810 ft
PIC - AER	28,940 ft	19,340 ft	14,100 ft	10,370 ft
Pulp - UG	26,550 ft	18,780 ft	14,200 ft	10,600 ft
Pulp - AER	25,160 ft	17,500 ft	13,050 ft	9,690 ft
Meters	19 AWG	22 AWG	24 AWG	26 AWG
PIC - UG	9,310 m	6,340 m	4,670 m	3,290 m
PIC - AER	8,820 m	5,890 m	4,290 m	3,160 m
Pulp - UG	8,090 m	5,720 m	4,320 m	3,230 m
Pulp - AER	7,660 m	5,330 m	3,970 m	2,950 m
38.5 dB @ 136 kHz				

Table 4.4.2-3: XCel-4a Span Reach

XCel-4a SPAN Reach (feet and meters)				
Feet	19 AWG	22 AWG	24 AWG	26 AWG
PIC - UG	24,850 ft	17,580 ft	13,650 ft	10,170 ft
PIC - AER	23,710 ft	16,660 ft	12,760 ft	9,380 ft
Pulp - UG	21,240 ft	15,520 ft	12,320 ft	9,800 ft
Pulp - AER	20,250 ft	14,750 ft	11,550 ft	9,080 ft
Meters	19 AWG	22 AWG	24 AWG	26 AWG
PIC - UG	7,570 m	5,350 m	4,160 m	3,090 m
PIC - AER	7,220 m	5,070 m	3,880 m	2,850 m
Pulp - UG	6,470 m	4,730 m	3,750 m	2,980 m
Pulp - AER	6,170 m	4,490 m	3,520 m	2,760 m
41.5 dB @ 230 kHz				

Table 4.4.2-2: XCel-12Span Reach

XCel-12 SPAN Reach (feet and meters)				
Feet	19 AWG	22 AWG	24 AWG	26 AWG
PIC - UG	25,160 ft	17,570 ft	13,460 ft	9,840 ft
PIC - AER	23,760 ft	16,590 ft	12,540 ft	9,050 ft
Pulp - UG	21,500 ft	15,580 ft	12,220 ft	9,520 ft
Pulp - AER	20,470 ft	14,750 ft	11,390 ft	8,780 ft
Meters	19 AWG	22 AWG	24 AWG	26 AWG
PIC - UG	7,660 m	5,350 m	4,100 m	2,990 m
PIC - AER	7,240 m	5,050 m	3,820 m	2,750 m
Pulp - UG	6,550 m	4,740 m	3,720 m	2,900 m
Pulp - AER	6,230 m	4,490 m	3,470 m	2,670 m
38.5 dB @ 196 kHz				

4.5 Step 5: The results of the design are shown in the three “RESULTS” message boxes. The first box indicates problems with individual spans, the second box indicates if there is enough total power, and the third box reports the calculated Reserve Power Ratio. The program indicates if the design is good by showing an “OK” within the first two boxes. If there are problems it will display a warning.

- The box labeled “Reserve Power Ratio” indicates how much power is available on a reserve basis. It must be either 0 or a positive number in order for the system to work reliably. The larger the number, the more available reserve power. A negative Reserve Power Ratio requires that a section be shortened or reconfigured, until the Ratio is zero or greater. The program also shows the total resistance (ohms) of the system and the total length for reference.
- If an “Over Power Budget” message is displayed it will be necessary to either reduce the cable length or reduce the number of elements in the total section from first to last unit. For example, placing an RTU instead of two ADR2s will save power. Another alternative is to use parallel power pairs, especially closer to the central office (See Section 9.0 of this document).
- Look at the “Span dB” for loss calculations. The maximum span loss for a XCel or GDSL system is stated in the Configur8r. Span lengths causing the Span dB to exceed the maximum, will trigger a message.

NOTE: When initially planning for reach of cable in a section (a line powered section) or for a span (between repeaters) some good rules of thumb can be applied:

- | | |
|-------------------------|-----------------------------------------|
| - Line powered Section: | Approximately 2,500 ohms to 3,000 ohms. |
| - Individual Span: | Approximately 1,000 ohms. |

4.6 Step 6: Additional options: you have the option at this point to collect reference values/information that can be useful during system turn-up or in the future for maintenance and troubleshooting purposes. his step reports the reference “Idle State” current and voltage values predicted for each span when the system is in an idle state, with no lines off hook. If you encounter trouble in turning up the system or if you suspect a new cable fault, comparing these values to those found by taking measurements in the field can provide clues as to the location of the trouble.

- This is accomplished by adjusting the for “initial current value” within the box in Step 2, so that the “Reserve Power Ratio” equals zero,
- The span results section now displays the individual span cable resistance, plus the current and voltage values for each span under the conditions of maximum load.

5. Instructions for Page 2 of each Configur8r Section/Worksheet

5.1 Each Worksheet has a page 2 at the bottom of the spreadsheet. This page provides and planning and tracking assistance to provide aid during installation, loop qualification and any later troubleshooting that may be required. This form was developed with the assistance of customers based on their experiences in tracking problems with particularly difficult loops.

Installation Note

Configur8r™ READ ME System Design Software



- 5.2 Below are the definitions and instructions for completing this form starting at the top of the page.
- **Page 2 for Design:**..... Fills in automatically from Name Your Loop at top of Worksheet.
 - **EXCHANGE:** Fills in automatically from top of Worksheet.
 - **WORK ORDER:**..... Fills in automatically from top of Worksheet.
 - **CABLE PAIRS:**..... Fills in automatically from top of Worksheet.
 - **REFERENCE FREQUENCY:**. Customer defined, FILL IN the blank. This is the reference frequency that test equipment uses to measure Actual Span Loss or signal loss.
Note: The XCel-8 operates at 136 kHz, the XCel-12 operates at 196 kHz, and the XCel-4a operates at 230 KHz. The Configur8r's Calculated Span Loss is based on measurements at these frequencies. XCel-8 and XCel-12 System attenuation (System Loss) is limited to 38.5 dB per repeated span at the above frequencies. The XCel-4a System is limited to 41.5 dB per repeated span. If Span Loss testing is made at other than the designated frequencies (136 kHz for XCel-8, 196 kHz for XCel-12 or 230 kHz for XCel-4a) then the actual frequency should be specified and loss measurements must be adjusted in accordance with appropriate cable curves to identify the delta based on this difference. For example 112 kHz (typical for 82A test equipment) results in a 35 dB Loss limit (approximately the same as the XCel-8's 38.5 dB limit at 136 kHz).
 - **SYSTEM TYPE:**..... Customer defined, FILL IN the blank i.e. Growth, S6B Repl., Etc.
 - **SYSTEM NUMBER(S):**..... Customer defined, FILL IN the blank
 - **PREPARED BY / DATE:**..... Customer defined, FILL IN the blank
 - **TESTED BY / DATE:** Customer defined, FILL IN the blank
- DSL per Span Test Objectives:** Recommended measurement test objectives for individual spans including:
- **Location Ground**..... Not to exceed 25 Ohms
 - **DSL Loop Resistance**..... Within 10% of calculated
 - **Unbalanced** Not less than 98% (resistance T-G compared to resistance R-G)
The following should be checked in each direction on a span.
 - **Insulation**..... Greater than or equal to 200 Mega-ohms per mile
 - **Resistance Fault** Greater than or equal to 99 Mega-ohms (T-R, T-G and R-G)
 - **Noise- Metallic (Nm)** Not to exceed 20 dBrc. User termination
 - **Power Influence (PI)** Not to exceed 95 dBrc. Use termination
 - **Span Loss** Must be within +/- 3 dB of the calculated value
 - **AC Inductance**..... Not to exceed 30 Vac T-G and R-G, and 1 Vac T-R. Test CO to System end
 - **DC Cross Battery** Less than 0.9 Vdc T-G, R-G and T-R
 - **TDR** If moisture suspected
- POTS Channel Test Objectives (per drop line):** Recommended measured objectives per line (at terminating NID)
- **On Hook DC Voltage**..... +/- 41 to 54 volts DC
 - **Drop Loop Current**..... Minimum of 20 mA. Drop attached.
 - **Channel Noise Metallic** Not to exceed 20 dBrc.
 - **Power Influence** Not to exceed 95 dBrc.
 - **Channel Loss** Not to exceed either 8.0 dB (TR-057) or 8.5 dB (some local practices).
- Span and System Information** Calculated and Actual Measurements for comparison on each electrical span for the loop on this worksheet.
- **From A Location**..... Customer defined, FILL IN the blank. The beginning location of the cable span for each repeated span. The first span is the C.O.
 - **To Z Location**..... Customer defined, FILL IN the blank. The end location of an individual cable span for each repeated span. This is also the beginning for the following span unless it is the last span.
 - **Terminal Z Location** Note to clarify actual placement of the span element; (pole XX, etc.)

- **... Loop Ohms**
 - **... Calculated** Fills in automatically from main Worksheet for each repeatered span.
 - **... Actual** Customer measured, FILL IN the blank, to compare against calculated. Measured Actual loop loss should be close to the calculated value. Should be: Calculated Loss – 75 ohms < Actual < Calculated + 25 ohms In all cases Actual should be within 10% of calculated
- **... Unbalance Resistance** This measurement compares the length of one conductor (T) to the other conductor (R). Comparative resistance per span should be greater than 98%.
- **... Insulation (MΩ) T/R/T-G/R-G:** Measurement is indicative of the integrity of the cables and can detect shield faults as well as moisture pockets in the cable core. Pairs should be meggered at 500 volt scale. All readings (T/R/T-G/R-G) must be 200 Mega-ohms per mile or greater. CAUTION: Follow cable pre-qualification instructions and equipment test procedures or damage to equipment and customer CPE can result.
- **... Span Loss Reading:** Insures loss specifications are not exceeded
 - **... Calculated** Fills in automatically from main Worksheet for each repeatered span.
 - **... Actual** Customer measured, FILL IN the blank, to compare against calculated. For each repeated span. Measured Actual should be +/- 3 dB of calc. value.

Noise CO – to - End: Insures noise specifications are not exceeded

- **... Nm (Noise Metallic)** Customer measured, FILL IN the blank. The circuit Metallic Noise objective is 20 dBrc or less. Measurement is to be made from the central office end with the far end terminated (use 600 or 900 ohms with a 2 µf capacitor).
- **... PI (Power Influence)** Customer measured, FILL IN the blank. The circuit Power Influence objective is 95 dBrc or less. Measurement is to be made from the central office end with the far end terminated (use 600 or 900 ohms with a 2 µf capacitor).
- **... T - G (AC Induction)** Customer measured, FILL IN the blank. AC volts on pair are to be read with a far end short to Ground. Reading for near end (T–G) should not exceed 30 volts AC.
- **... R - G (AC Induction)** Customer measured, FILL IN the blank. AC volts on pair are to be read with a far end short to Ground. Reading for near end (R–G) should not exceed 30 volts AC.

POTS and Subscriber and Drop Information:

- **... Channel Number** Customer FILL IN the blank. References the XCel or GDSL channel number.
- **... Phone Number** Customer FILL IN the blank. References the subscriber local phone number.
- **... Customer Address** Customer FILL IN the blank. References the subscriber local address.
- **... Current mA** Customer FILL IN the blank. Minimum of 20 mA with drop attached.
- **... Loss dB** Customer FILL IN the blank. Per Local Practice, not to exceed 8.0 dB (TR-057) or per local practice.
- **... Noise:**
 - **... Nm (Noise Metallic)** Customer measured, FILL IN the blank. The circuit Metallic Noise objective is 20 dBrc or less.
 - **... PI (Power Influence)** Customer measured, FILL IN the blank. The circuit Power Influence objective is 95 dBrc or less.
- **... DC Volts T - R** Customer FILL IN the blank. Should be between 41 to 54 volts DC

Installation Note

Configur8r™ READ ME System Design Software



6. Printing

Go to “Print Setup” and select ‘Portrait’. Print the results of this Worksheet.

7. Worksheets #2 & #3

If the system being engineered uses Locally Powered Repeaters, repeat **Step 2** – **Step 6** on Worksheet #2 and Worksheet #3.

8. Saving Your Design

Use “Save As” to save the design file as any name desired. We suggest you open a new spreadsheet for each new design, rather than changing an existing sheet.

9. Parallel Power Pair

If limited by ohms, the range of the XCel or GDSL system can be extended by using an additional cable pair in any or all spans. This is NOT an express power hook-up, but rather tying two cable pairs together for one or more spans to reduce the resistance. Designing systems with parallel power is accomplished in two steps. First, input the actual length and gauge of the cable span and ensure the attenuation is within spec. Now decrease the cable gauge of the span by one size but keep the length the same. For example, to use two pairs of 26 gauge, run the Configur8r with 26 gauge to make sure the attenuation loss is in spec and then change the gauge from 26 to 24 gauge to see the impact on the power budget. If the total span length is designed to 38.5 dB the span must be shortened by 5 dB to compensate for the additional attenuation.

10. Pulp Cable

10.1 The standard version of the *Configur8r* has no provision for loops with pulp cable. Pulp cable resistance is the same as PIC but the attenuation loss is higher.

10.2 For planning spans with pulp cable, planners and engineers can easily accommodate the adjustment in greater attenuation with one of the following two methods:

10.2.1 If a span is made up of a single grade of pulp cable (example: 22 AWG Pulp Cable) use the tables for Cable Span Distances for maximum reach values provided in the tables to engineer spans:

- XCel-8, GDSL-8 and GDSL-3i Span Distances: [Table 4.4.2-1](#)
- XCel-12 Cable Span Distances: [Table 4.4.2-2](#)
- XCel-4a Cable Span Distances: [Table 4.4.2-3](#)

10.2.2 For spans with mixed gauges or with only a portion of the span using pulp cable, shorten the maximum span length by reducing the loss margin when using the Configur8r by 2 dB. Example, for the XCel-8 with a designated span margin of 38.5 dB, design the span to 36.5 dB maximum.

10.3 If you have appreciable amounts of pulp cable please contact GoDigital Product Support.

11. C-Wire and/or Open Wire

GoDigital does not publish specifications for XCel Systems using C-Wire or Open Wire loops, however in some rural locations several GoDigital customers have had success in installing XCel System loops over very long distances with these options.

11.1 Both the resistance (affecting line powering downstream and thus overall reach) and also the signal attenuation (influencing the distance between repeaters) are very low, enabling long loops. Feasible span lengths between repeaters may be as much as two times (2 X) or more, the lengths published for 19 AWG cable in the GoDigital specifications.

11.2 If using C-Wire or Open Wire the following considerations are recommended by GoDigital:

11.2.1 The primary performance considerations that arise with these types of cable are:

- Power Influence (not to exceed 95 dBmrc), and
- AC Inductance (not to exceed 30 Vac T-G and R-G, and 1 Vac T-R) from nearby power distribution lines, especially high voltage lines.

- 11.2.2 C-Wire and Open Wire are very vulnerable to this influence. In response to this, AC drain coils should be used at each element (repeater and remote terminal), and AC drain coils may also be needed mid-span to eliminate problems.
- 11.2.3 The Configur8r can be used for the 19 AWG span lengths in virtually all cases and this will result in an extremely conservative estimate of reach. Longer spans may be feasible, depending on the quality and environment of the wire.
- 11.2.4 Any C-Wire or Open wire span being considered for use with an XCel System should be “Pre-Qualified” in accordance with the specifications in Section 4 of this System Practice.

12. Locally Powered Units

Locally powered units consist of the locally powered Straight Through Repeater (STR LP). These units are used to further extend the long loop applications supported by the GoDigital XCel or GDSL-8 system, by adding additional powered Sections to the XCel or GDSL system. On sheet2 and sheet3 of the Configur8r, the first unit must be a locally powered unit. The span prior to the locally powered unit is the cable connecting to the last unit on the previous sheet. You can have a maximum of two locally powered units in a XCel or GDSL-8 system.

13. Sample Configur8r

The following pages display the actual format of the Configur8r.

NOTE: The cost information is user-entry. The program will calculate total cost if you input individual unit prices.

Installation Note

Configur8r™ READ ME System Design Software



13.1 Example of Worksheet #1, page 1: See READ ME paragraph 4 for Instructions

GoDigital XCel-8 System Configur8r™ for 260V DSL with Local Power, Drop Test (990259-01)

Name Your Loop:			
Additional User Info:	OSP Cable/Pair:	Exchange:	Work Order #:

General Information: This Configur8r is designed for long loops that can be extended using locally-powered repeaters on sheet2 and sheet3.

The first sheet starts with a line card, and subsequent sheets start with a powered repeater. Each sheet ends with the LAST unit before the powered repeater. Each subsequent sheet begins with the copper span from the last unit of the preceding section, and that span is terminated by the powered repeater on the first span in the new sheet. GoDigital GDSL-8 is limited to a MAXIMUM of 8 of the following smart elements: ADR4, TAD4, RTU8.

Before you begin: Lay out your loop on a sheet of paper. Identify the desired locations of drops and select the type of GDSL-8 field units you intend to use. Then record all lengths and gauges for all connecting cable.

Step 1: This configur8r measures loop distance in feet by default. To use metric, type 'M' here:

Step 2: Enter into cell P26 a unit type and number of drops for the LAST unit in this sheet. This activates the power calculator.

- Unit type: S STR or Pole Mount Straight Through Repeater
- SP STRM or 239-Plug Straight Through Repeater
- A4E ADR4 or Add/Drop Repeater 4 with Extended Drops
- R8E RTU8 or Remote Terminal Unit 8 with Extended Drops
- T4E TAD4 or Terminal Add/Drop Unit 4 with Extended Drops

Error Monitor: Your entry of unit type in line 26 is correct ONLY if line 27 says: "OK". Entry of last unit (right column) is REQUIRED.

Step 3: Enter the number 0.094 in box H71 if it is not 0.094.

Step 4: Go back to cell B26 and enter the FIRST unit in this sheet. Go down to B39 and enter cable lengths.

INFO: If the cable to reach your first drop unit exceeds the dB loss limit, the program will ask you to place a repeater. In this case, move your drop unit over to the right one span and continue across to the right until all drop units are placed.

Step 5: Assign subscriber drops to each drop unit according to whether they are 'long' or 'short'. A short drop is 270 ohms or less (plus 430 ohm telephone set). In terms of length, a 'short' drop is 7,300 feet or less on 22 gauge, or 4,600 feet or less on 24 gauge dropwire.

NOTE on ADRs: A maximum of 3 ADRs per line powered section is recommended for reliable linking.

First GDSL-8 Unit:	<input type="text"/>	Next Unit:	<input type="text"/>	Next Unit:	<input type="text"/>	Next Unit:	<input type="text"/>	Next Unit:	<input type="text"/>	Next Unit:	<input type="text"/>	Next Unit:	<input type="text"/>	Last Unit:	<input type="text"/>
Error Monitor:	ENTER	ENTER	ENTER	ENTER	ENTER	ENTER	ENTER	ENTER	ENTER	ENTER	ENTER	ENTER	ENTER	REQUIRED	REQUIRED
Short Drops:	0	0	0	0	0	0	0	0	0	0	0	0	0	0	0
Extended Drops:	0	0	0	0	0	0	0	0	0	0	0	0	0	0	0

Here is the summary of the number of working lines for the total system: (Maximum of 8 active lines)

Span	0	Span	0	Span	0	Span	0	Span	0	Span	0	Span	0	Last Span	1
gauge	Ft Pic	gauge	Ft Pic	gauge	Ft Pic	gauge	Ft Pic	gauge	Ft Pic	gauge	Ft Pic	gauge	Ft Pic	gauge	Ft Pic
10810 ft max 26 UG	0	26 UG	0	26 UG	0	26 UG	0	26 UG	0	26 UG	0	26 UG	0	26 UG	0
10350 ft max 26 Aer	0	26 Aer	0	26 Aer	0	26 Aer	0	26 Aer	0	26 Aer	0	26 Aer	0	26 Aer	0
15300 ft max 24 UG	0	24 UG	0	24 UG	0	24 UG	0	24 UG	0	24 UG	0	24 UG	0	24 UG	0
14100 ft max 24 Aer	0	24 Aer	0	24 Aer	0	24 Aer	0	24 Aer	0	24 Aer	0	24 Aer	0	24 Aer	0
20800 ft max 22 UG	0	22 UG	0	22 UG	0	22 UG	0	22 UG	0	22 UG	0	22 UG	0	22 UG	0
19340 ft max 22 Aer	0	22 Aer	0	22 Aer	0	22 Aer	0	22 Aer	0	22 Aer	0	22 Aer	0	22 Aer	0
30550 ft max 19 UG	0	19 UG	0	19 UG	0	19 UG	0	19 UG	0	19 UG	0	19 UG	0	19 UG	0
28950 ft max 19 Aer	0	19 Aer	0	19 Aer	0	19 Aer	0	19 Aer	0	19 Aer	0	19 Aer	0	19 Aer	0
Span ft:	0	Span ft:	0	Span ft:	0	Span ft:	0	Span ft:	0	Span ft:	0	Span ft:	0	Span ft:	0
Span dB:	0.5	0.0	0.0	0.0	0.0	0.0	0.0	0.0	0.0	0.0	0.0	0.0	0.0	0.0	0.0
Feedback:	OK to add cable	OK to add cable	OK to add cable	OK to add cable	OK to add cable	OK to add cable	OK to add cable	OK to add cable	OK to add cable	OK to add cable	OK to add cable	OK to add cable	OK to add cable	OK to add cable	OK to add cable

Enter initial current value of "0.094" in this box: **Never exceed 0.094!!**

Step 6: Results Each Span is OK Power Calculator is Off Reserve Power Ratio:

Total Resistance of this section is: 11 Ohms Total Length of this section is: 200 feet

Total Resistance of all sections is: 11 Ohms Total Length of all sections is: 200 feet

Step 7: To check idle state current & voltage: 1st type 'y' here Second, get cell P72 to equal to 'Zero' by reducing the current value in

cell H71. You can do this manually or use the "Goal Seek" command under "Tools". To go back worst case measurement, clear cell H80.

Span:	0	Span:	0	Span:	0	Span:	0	Span:	0	Span:	0	Span:	0	Span:	1
Ohms	11	Ohms	0	Ohms	0	Ohms	0	Ohms	0	Ohms	0	Ohms	0	Ohms	0
Current	0.094	Current	0.094	Current	0.094	Current	0.094	Current	0.094	Current	0.094	Current	0.094	Current	0.094
Span volts	254	Span volts	254	Span volts	254	Span volts	254	Span volts	254	Span volts	254	Span volts	254	Span volts	254

Customer info	Type of Service	Phone Number	Remarks	Equipment List	P/N	Quantity	Spares	Total Quantity	Cost Ea.	Total
Channel 1		-		SHLF H 19	990117	0	0	0	0	0.00
Channel 2		-		SHLF H 23	990118	0	0	0	0	0.00
Channel 3		-		ACU MOD H CB	990249	0	0	0	0	0.00
Channel 4		-		STREAKER	990210	0	0	0	0	0.00
Channel 5		-		CTU H 8P M9 USW	990124	1	0	1	0	0.00
Channel 6		-		STR	990064	0	0	0	0	0.00

13.2 Example of Worksheet #1, page 2 – See READ ME paragraph 5 for Instructions

GoDigital GDSL XCel-8 Configur8r Program

Page 2 for Design: 0

Qualify the cable pair to be used for this installation using the following criteria. If the pair does not meet these criteria you may have immediate trouble in achieving system linking or in noise quality, or you may have swinging trouble in the future as temperature or moisture variations cause out-of-tolerance conditions.

Exchange		System Type	
Work Order		System Number(s)	
Cable Pairs		Prepared by / Date	
Reference Frequency		Tested by / Date	

Circuit Test Objectives (per Span)

DSL Loop Resistance	Within 10% of calculated.
Unbalance	Not to exceed 10 ohms.
Insulation	200 MOhm per mile.
Noise Metallic (Nm)	Not to exceed 20 dBmrc. Use termination.
Power Influence (PI)	Not to exceed 80 dBmrc. Use termination.
Span Loss	Must be within +/- 3 dB of the calculated value.
AC Inductance	Not to exceed 25 volts AC. Test from CO to System end.
Location Ground	Not to exceed 25 ohms.
TDR	If moisture is suspected.

NID Test Objectives

On Hook DC Voltage	+/-41 to 54 volts DC.
Drop Loop Current	Minimum of 20 mA. Drop attached.
Channel Noise Metallic	Not to exceed 20 dBmrc.
Power Influence	Not to exceed 80 dBmrc.
Channel Loss	Not to exceed 8.5 dB.

Span and System Information

From A Location	To Z Location	Terminal Z Location	Loop Ohms		Unbalance Actual	Insulation (MΩ)			Span Loss Reading	
			Calculated	Actual		T-G	R-G	T-R	Calculated	Actual
C.O.			11						0.5	
			Unused						0.0	
			Unused						0.0	
			Unused						0.0	
			Unused						0.0	
			Unused						0.0	
			0						0.0	
C.O.			XXXXXXX	XXXXXXX	XXXXXXX	XXX	XXX	XXX	XXXXXX	XXXXX

Noise CO-to-End

Nm	PI	T-G	R-G

Subscriber and Drop Information

Channel Number	Phone Number	Customer Address	Curr mA	Loss dB	Noise		DC Volts	
					Nm	PI	T-R	
1	-							
2	-							
3	-							
4	-							
5	-							
6	-							
7	-							
8	-							

Installation Note

Configur8r™ READ ME System Design Software



13.3 Example of Worksheet #2 & 3, page 1: See READ ME paragraph 4 for Instructions

GoDigital XCel-8 System Configur8r™ for 260V DSL with Local Power, Drop Test (990259-01)

1st Powered Repeater Section:			
Additional User Info:	OSP Cable/Pair:	Exchange:	Work Order #:

General Information: This Configur8r is designed for long loops that can be extended using locally-powered repeaters on sheet2 and sheet3.

The first sheet starts with a line card, and subsequent sheets start with a powered repeater. Each sheet ends with the LAST unit before the powered repeater.

Each subsequent sheet begins with the copper span from the last unit of the preceeding section, and that span is terminated by the powered repeater on the first span in the new sheet. GoDigital GDSL-8 is limited to a MAXIMUM of 8 of the following smart elements: ADR4, TAD4, RTU8.

Before you begin: Lay out your loop on a sheet of paper. Identify the desired locations of drops and select the type of GDSL-8 field units you intend to use.

Then record all lengths and gauges for all connecting cable.

Step 1: Enter into cell P25 a unit type and number of drops for the LAST unit in this sheet. This activates the power calculator.

- Unit type:** S STR or Pole Mount Straight Through Repeater
- SP STRM or 239-Plug Straight Through Repeater
- A4E ADR4 or Add/Drop Repeater 4 with Extended Drops
- PS STRLP(2) or Pole Mount Straight Through Repeater - Locally Powered
- R8E RTU8 or Remote Terminal Unit 8 with Extended Drops
- T4E TAD4 or Terminal Add/Drop Unit 4 with Extended Drops

Error Monitor: Your entry of unit type in line 26 is correct ONLY if line 27 says: "OK". Entry of last unit (right column) is REQUIRED.

Step 2: Enter the number 0.094 in box H72 if it is not 0.094.

Step 3: Go back to cell B26 and enter the FIRST unit in this sheet. It MUST be a PS. Go down to B39 and enter cable lengths.

INFO: If the cable to reach your first drop unit exceeds the dB loss limit, the program will ask you to place a repeater.

In this case, move your drop unit over to the right one span and continue across to the right until all drop units are placed.

Step 4: Assign subscriber drops to each drop unit according to whether they are 'long' or 'short'. A short drop is 270 ohms or less (plus 430 ohm telephone set). In terms of length, a 'short' drop is 7,300 feet or less on 22 gauge, or 4,600 feet or less on 24 gauge dropwire.

NOTE on ADRs: A maximum of 3 ADRs per line powered section is recommended for reliable linking.

1st Powered Repeater:	Next Unit:	Next Unit:	Next Unit:	Next Unit:	Next Unit:	Next Unit:	Next Unit:	Last Unit:
Error Monitor:	ENTER	ENTER	ENTER	ENTER	ENTER	ENTER	ENTER	REQUIRED
Short Drops:	0	0	0	0	0	0	0	0
Extended Drops:	0	0	0	0	0	0	0	0

Here is the summary of the number of working lines for the total system:														0		(Maximum of 8 active lines)	
Span	0	Span	0	Span	0	Span	0	Span	0	Span	0	Span	0	Last Span	1		
gauge	Ft Pic	gauge	Ft Pic	gauge	Ft Pic	gauge	Ft Pic	gauge	Ft Pic	gauge	Ft Pic	gauge	Ft Pic	gauge	Ft Pic		
10810 ft max 26 UG	0	26 UG	0	26 UG	0	26 UG	0	26 UG	0	26 UG	0	26 UG	0	26 UG	0		
10350 ft max 26 Aer	0	26 Aer	0	26 Aer	0	26 Aer	0	26 Aer	0	26 Aer	0	26 Aer	0	26 Aer	0		
15300 ft max 24 UG	0	24 UG	0	24 UG	0	24 UG	0	24 UG	0	24 UG	0	24 UG	0	24 UG	0		
14100 ft max 24 Aer	0	24 Aer	0	24 Aer	0	24 Aer	0	24 Aer	0	24 Aer	0	24 Aer	0	24 Aer	0		
20800 ft max 22 UG	0	22 UG	0	22 UG	0	22 UG	0	22 UG	0	22 UG	0	22 UG	0	22 UG	0		
19340 ft max 22 Aer	0	22 Aer	0	22 Aer	0	22 Aer	0	22 Aer	0	22 Aer	0	22 Aer	0	22 Aer	0		
30550 ft max 19 UG	0	19 UG	0	19 UG	0	19 UG	0	19 UG	0	19 UG	0	19 UG	0	19 UG	0		
28950 ft max 19 Aer	0	19 Aer	0	19 Aer	0	19 Aer	0	19 Aer	0	19 Aer	0	19 Aer	0	19 Aer	0		
Span ft:	0	Span ft:	0	Span ft:	0	Span ft:	0	Span ft:	0	Span ft:	0	Span ft:	0	Span ft:	0		
Span dB:	0.0	Span dB:	0.0	Span dB:	0.0	Span dB:	0.0	Span dB:	0.0	Span dB:	0.0	Span dB:	0.0	Span dB:	0.0		
Feedback:	OK to	Feedback:	OK to	Feedback:	OK to	Feedback:	OK to	Feedback:	OK to	Feedback:	OK to	Feedback:	OK to	Feedback:	OK to		
Feedback:	add cable	Feedback:	add cable	Feedback:	add cable	Feedback:	add cable	Feedback:	add cable	Feedback:	add cable	Feedback:	add cable	Feedback:	add cable		

Enter initial current value of "0.094" in this box: 0.094 **Never exceed 0.094!!**

Step 5: Results Each Span is OK Power Calculator is Off Reserve Power Ratio: 100

Total Resistance of this section is: 0 Ohms Total Length of this section is: 0 feet

Total Resistance of all sections is: 11 Ohms Total Length of all sections is: 200 feet

Step 6: To check idle state current & voltage: 1st, type 'y' here Second, get cell P73 to equal to 'Zero' by reducing the current value in

cell H72. You can do this manually or use the "Goal Seek" command under "Tools". To go back worst case measurement, clear cell H81.

Span:	0	Span:	0	Span:	0	Span:	0	Span:	0	Span:	0	Span:	0	Span:	1
Ohms	0	Ohms	0	Ohms	0	Ohms	0	Ohms	0	Ohms	0	Ohms	0	Ohms	0
Current	0.000	Current	0.094	Current	0.094	Current	0.094	Current	0.094	Current	0.094	Current	0.094	Current	0.094
Span volts	254	Span volts	255	Span volts	255	Span volts	255	Span volts	255	Span volts	255	Span volts	255	Span volts	255

User Note															

GoDigital GDSL XCel-8 Configur8r Program

13.4 Example of Worksheet #2 & 3, page 2 – See READ ME paragraph 5 for Instructions

GoDigital GDSL XCel-8 Configur8r Program

Page 2 for Design: 0

Qualify the cable pair to be used for this installation using the following criteria. If the pair does not meet these criteria you may have immediate trouble in achieving system linking or in noise quality, or you may have swinging trouble in the future as temperature or moisture variations cause out-of-tolerance conditions.

Exchange		System Type	
Work Order		System Number(s)	
Cable Pairs		Prepared by / Date	
Reference Freq.		Tested by / Date	

Circuit Test Objectives (per Span)

DSL Loop Resistance	Within 10% of calculated.
Unbalance	Not to exceed 10 ohms.
Insulation	200 MOhm per mile.
Noise Metallic (Nm)	Not to exceed 20 dBrc. Use termination.
Power Influence (PI)	Not to exceed 80 dBrc. Use termination.
Span Loss	Must be within +/- 3 dB of the calculated value.
AC Inductance	Not to exceed 25 volts AC. Test from CO to System end.
Location Ground	Not to exceed 25 ohms.
TDR	If moisture is suspected.

NID Test Objectives

On Hook DC Voltage	+/-41 to 54 volts DC.
Drop Loop Current	Minimum of 20 mA. Drop attached.
Channel Noise Metallic	Not to exceed 20 dBrc.
Power Influence	Not to exceed 80 dBrc.
Channel Loss	Not to exceed 8.5 dB.

Span and System Information

From A Location	To Z Location	Terminal Z Location	Loop Ohms		Unbalance	Insulation (MΩ)			Span Loss Reading
			Calculated	Actual	Actual	T-G	R-G	T-R	Calculated
C.O.			Unused						0.0
			Unused						0.0
			Unused						0.0
			Unused						0.0
			Unused						0.0
			Unused						0.0
			Unused						0.0
C.O.			XXXXXXX	XXXXXXX	XXXXXXX	XXX	XXX	XXX	XXXXXX

Noise CO-to-End

Nm	PI	T-G	R-G

Subscriber and Drop Information

Channel Number	Phone Number	Customer Address	Curr mA	Loss dB	Noise		DC Volts T-R
					Nm	PI	
1	-						
2	-						
3	-						
4	-						
5	-						
6	-						
7	-						
8	-						

Installation Note

Configur8r™ READ ME System Design Software



This page intentionally blank

CONTACTING GODIGITAL

**GoDigital Networks Corporation
41652 Boscell Road
Fremont, CA 94538**

1-800-297-2424

1-510-979-2200

Fax 510-226-8785

Email

GoDigital Sales: sales@godigital.com

Technical Assistance: product.support@godigital.com