

1. Purpose

This document provides installation instructions for ACU MOD H AD Alarm Cards (“ACUs”). This document is provided with each ACU shipped to customers and is also available separately. In addition, an up to date copy is included as an attachment to the *XCel System Practice* with each XCel COT Shelf shipped. GoDigital recommends that one copy of the complete *System Practice* be kept in each Central Office.

2. Products

This Installation Note is relevant for the following GoDigital products:

System / Product Name	Part #	Description
XCel Multi-Service Shelf Common Card		
ACU MOD H AD	990249-A	ACU Supporting XCel Advanced Diagnostics Features

Figure 1
ACU MOD H AD Functional Interface Diagram

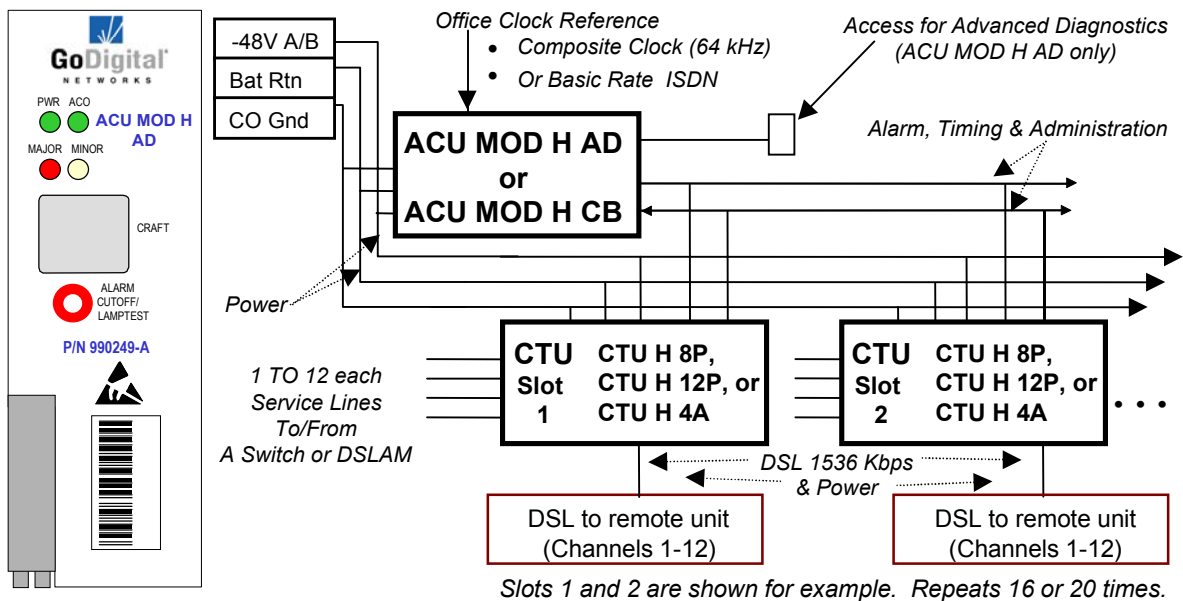

3. Overview

The ACU card is used for the GoDigital® XCel Multi-Service Shelf, which supports CTU line cards for XCel system, including the XCel™-8, XCel-12 and XCel-4a. The ACU card provides alarm indications and reporting for the CTU cards in the Multi-Service Central Office Shelf, and also provides a timing reference clock to all CTU card slots when an external clock has been provided via the appropriate backplane connector. The ACU MOD H AD has the capability to derive a clock from a 64 kHz composite clock or from a Basic Rate ISDN line served from a switch. An ISDN source is typically used when a composite clock is not available in an office or remote location. The AD version of the ACU also supports serial port access for PC-based XCel Advanced Diagnostic features, and also for software download for new XCel Systems.

A block diagram of the shelf connectivity for a Multi-Service Shelf, illustrated at the card slot level, when hosting XCel CTUs, is provided in Figure 1.

NOTE: The ACU MOD H AD card **MUST BE** installed in the Multi-Service Shelf for normal full feature operation of the XCel System. If the ACU is not installed:

- Alarms will not be collected from the CTUs and no contact alarms will function.
- The enhanced V.90 modem performance in XCel POTS CTUs will not be fully functional without the timing reference feed from the ACU MOD H AD and its timing source.

Installation Note

XCel Alarm Control Unit (ACU MOD H AD)

4. Summary of Installation Steps – See Section 5 for Detailed Installation

- 4.1 Unpack and Inspect the ACU MOD H AD Alarm Card.
- 4.2 Verify and/or Adjust the ACU Switch Settings:
 - 4.2.1 Set the **ALARM THRESHOLD** on the “SW3” switch on the card.
 - 4.2.2 Set the **EXTERNAL CLOCK SELECT** on the “SW2” switch on the card.
 - 4.2.3 Set the **EXTERNAL CLOCK CONFIGURATION** on the “SW4” switch on the card.
 - 4.2.4 Verify the 19” or 23” Multi-Service Shelf is properly installed and grounded.
- 4.3 Plug in the ACU to the Multi-Service Shelf

5. Installation

5.1 UNPACK and INSPECT the ACU Alarm Card

- Make a visual check of the newly opened ACU card for obvious shipping damage.
- Visually check the card to ensure that it is the correct unit for your shelf.

5.2 VERIFY or ADJUST the ACU Switch Settings

There are THREE settings on the ACU that must be verified and/or adjusted prior to installing the ACU. These settings are the **Alarm Threshold Setting**, the **External Clock Select**, and the **External Clock Configuration**. Figure 2 below shows the location of the three switch settings that need to be verified or set. In addition, the following pages, paragraphs 5.2.1 – 5.2.3 have detailed instructions on the individual switch setting options.

NOTE: The earlier version of the ACU (Part Number 990113) is subject to all of the same switch settings except the ISDN option.

Figure 2
Location of SW2, SW3 and SW4 on the on ACU MOD H AD Alarm Card

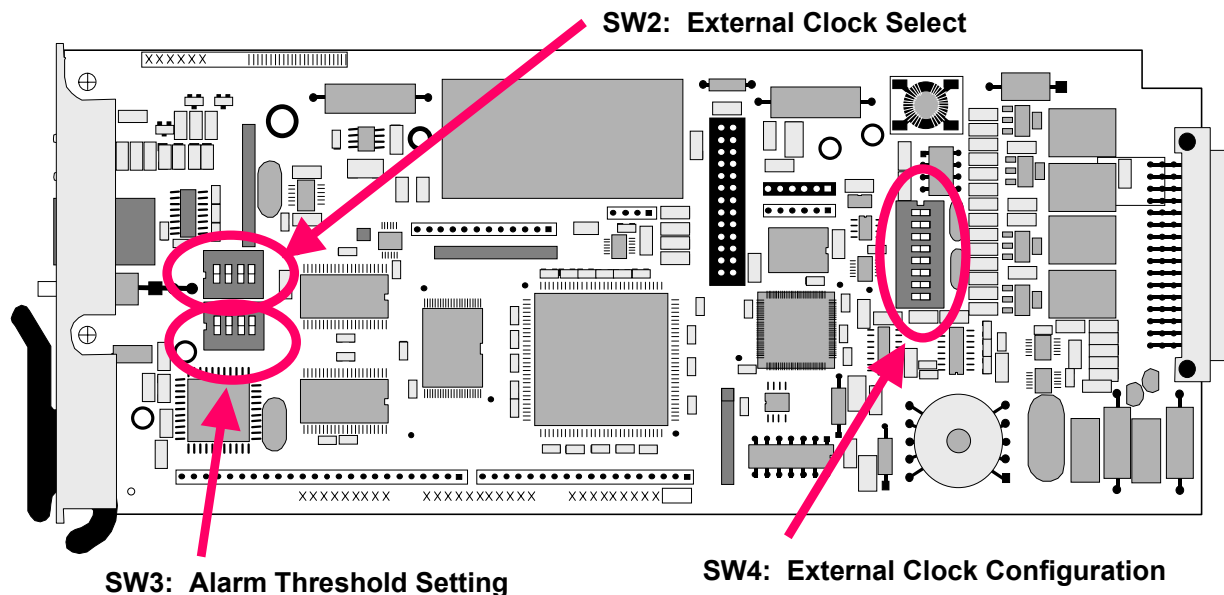

- 5.2.1 Set the **ALARM THRESHOLD** on the “SW3” Switch.
 On the ACU Card the selector switch 3 “SW3” should have either all positions in the “OFF” position or only one switch in the “ON” position. The Factory DEFAULT Setting is 2.

Figure 3
Location of SW3 on ACU for ALARM THRESHOLD SETTING

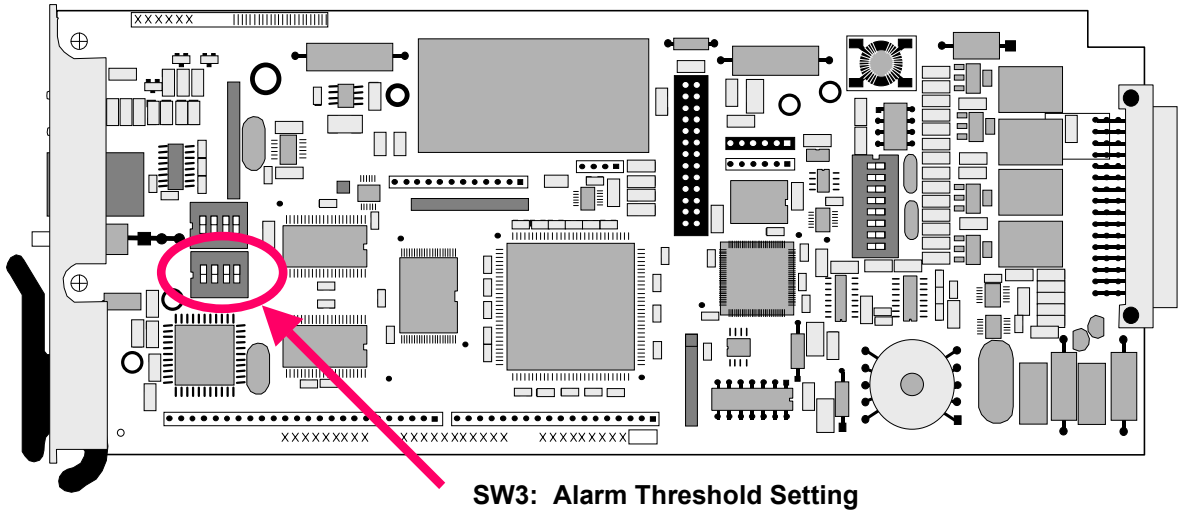

Table 1
Major ALARM THRESHOLD SETTINGS for Switch 3

990249-A ACU MOD H AD Alarm Threshold Settings.					
The Threshold setting establishes the level for triggering a MAJOR alarm in the shelf. A major alarm is defined by the number of CTUs, which can be in MINOR alarm before the ACU MOD H AD card indicates an alarm condition. The threshold may be set to 0, 1, 2, 3 or 4 CTUs in MINOR alarm condition. When a major alarm condition occurs, the MAJOR ALARM LED lamp on the faceplate illuminates and the two alarm relays (Audible and Visual) are activated to close. Five levels are available to select from:					
Threshold	<u>1</u>	<u>2</u>	<u>3</u>	<u>4</u>	Description of Alarm Threshold
0	OFF	OFF	OFF	OFF	Any one or more CTUs in a MINOR alarm condition will trigger the MAJOR alarm.
1	ON	OFF	OFF	OFF	One CTU in a MINOR alarm condition will not trigger a MAJOR alarm, but two or more CTUs in a MINOR alarm condition will trigger a MAJOR alarm.
2	OFF	ON	OFF	OFF	<u>Factory Default Setting:</u> Two CTUs in a MINOR alarm condition will not trigger a MAJOR alarm, but three or more CTUs in a MINOR alarm condition will trigger a MAJOR alarm.
3	OFF	OFF	ON	OFF	Three CTUs in a MINOR alarm condition will not trigger a MAJOR alarm, but four or more CTUs in a MINOR alarm condition will trigger a MAJOR alarm.
4	OFF	OFF	OFF	ON	Four CTUs in a MINOR alarm condition will not trigger a MAJOR alarm, but five or more CTUs in a MINOR alarm condition will trigger a MAJOR alarm.

Installation Note

XCel Alarm Control Unit (ACU MOD H AD)



5.2.2 Set the **EXTERNAL CLOCK SELECT** on the “SW2” Switch.

NOTE: Detailed Timing Reference Signal Specifications are provided in Paragraph 9 of this Install Note, and also in the Specifications Section of the XCel System Practice.

Figure 4 shows the location of the EXTERNAL CLOCK SELECT switch (SW2) on the ACU.

Figure 4
Location of SW2 on ACU MOD H AD for EXTERNAL CLOCK SELECT

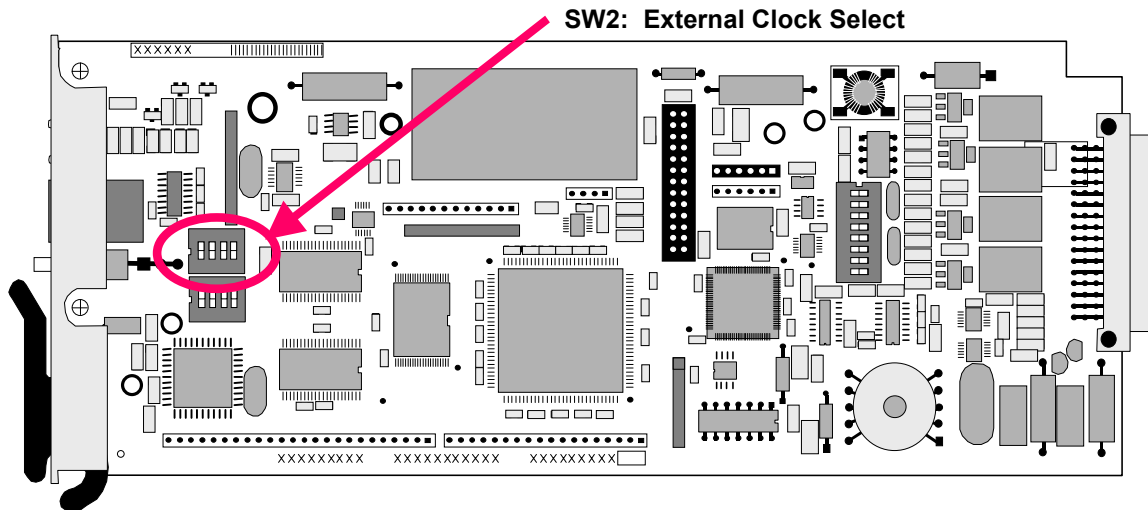

Table 2
EXTERNAL CLOCK SELECT Settings for SW2 on the ACU MOD H AD

990249 ACU MOD H AD	Timing Reference “Clock” settings.				
The ACU MOD H AD has the capability to derive a network clock from <u>either</u> a Composite Clock or from an ISDN line. A clock source is not required for POTS without V.90 support. The factory default setting for the ACU is for “Composite Clock”. The below table shows the settings for the ACU MOD H AD Timing Reference settings:					
<u>External Clock Select</u>	<u>1</u>	<u>2</u>	<u>3</u>	<u>4</u>	<u>Description of External Clock Select</u>
Composite Clock	OFF	ON	OFF	ON	<u>Factory Default Setting:</u> Balanced Composite Clock reference to wire wrap pins on backplane TIMING 1 connector.
ISDN	ON	ON	ON	OFF	ISDN line from Switch to wire wrap pins on backplane TIMING 1 connector.

NOTE: The earlier version of the ACU (Part Number 990113) is subject to all of the same switch settings except the ISDN option.

5.2.3 Set **EXTERNAL CLOCK CONFIGURATION** on the “SW4” Switch.
Figure 5 shows the location of the EXT. CLOCK CONFIGURATION Switch (SW4) on the ACU.

Figure 5
Location of SW4 for EXTERNAL CLOCK CONFIGURATION

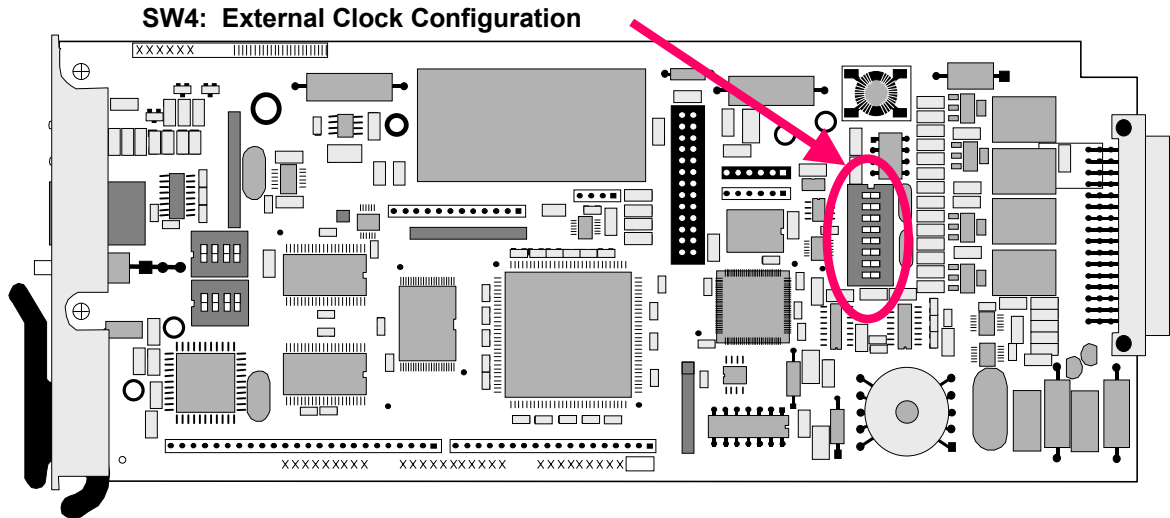

Table 3
EXTERNAL CLOCK CONFIGURATION Settings for SW4 on ACU MOD H AD

990249	ACU MOD H AD	<u>External Clock Configuration</u>							
External Clock Configuration									
<u>Select</u>	<u>1</u>	<u>2</u>	<u>3</u>	<u>4</u>	<u>5</u>	<u>6</u>	<u>7</u>	<u>8</u>	<u>Description</u>
Comp. Clock With Termination	OFF	ON	OFF	ON	ON	ON	ON	OFF	<u>Factory Default Setting</u> Composite Clock configuration setting for a Single Shelf alone, or for a shelf at the end of a daisy chained Clock.
Comp Clock Without Termination	OFF	ON	OFF	ON	ON	OFF	OFF	OFF	Daisy chained Composite Clock setting for an intermediate Shelf in a daisy chained configuration with the same Composite Clock feed.
ISDN	ON	OFF	ON	OFF	OFF	OFF	ON	OFF	ISDN as a Clock Reference. Can NOT be daisy chained. With an ISDN source, each XCel Shelf must have it's own ISDN reference feed.

NOTE: The earlier version of the ACU (Part Number 990113) is subject to all of the same switch settings except the ISDN option.

Installation Note

XCel Alarm Control Unit (ACU MOD H AD)



5.3 VERIFY the 19” or 23” MULTI-SERVICE SHELF is properly INSTALLED and GROUNDED.
This must include:

- Securely mounted to the relay rack
- -48V DC Battery is properly connected to the backplane
- Proper grounds are connected to the grounding points on the backplane
- Clock source is connected to the “Timing 1” wire wrap pins.
- Major and Minor Alarms are properly connected to the wire wrap pins.

5.4 PLUG IN the ACU to the Multi-Service Shelf

The ACU card plugs into the upper right-most slot of the shelf, and is required for normal shelf operation. This is the **ONLY** slot that will support the ACU plug in.

NOTE: The lower common card slot is keyed to prevent the ACU from seating. This second common slot is not used for XCel Multi-Service COT initial applications.

6. Troubleshooting

- If the POWER LED lamp does not illuminate, or if the card otherwise does not function, check to see that the CO Shelf is wired and powered up correctly.
- If the alarm relays fail to close when in an alarm condition, check to see that the alarm contacts were wired correctly on the backplane, and that they extend to the Central Office Alarm System.
- Also check for the correct setting of the alarm threshold switch.
- See also the Troubleshooting Section of the *System Practice*.

7. ACU LED and Alarm Indications

Illumination of the POWER LED lamps on the ACU card verifies proper operation. Each ACU MOD H AD has four LEDs and an Alarm Cutoff and Lamp Test button on the card faceplate. Depressing the Alarm Cutoff (ACO) button on the ACU faceplate will open the Audible Alarm relay and light the ACO LED. This LED will stay illuminated until the MAJOR or MINOR alarm is cleared.

**Table 4
ACU MOD H AD LEDs**

LED Name	Color
POWER	Green
ACO	Green
MAJOR	Red
MINOR	Yellow

- Upon initial insertion and power up, and until a XCel link is established for the first time, a CTU will **NOT** go into an alarm condition and no alarm will be reported to the ACU.
- Audible Alarms may be canceled by pushing the ACO (Alarm Cut-Off) button on the ACU faceplate.
- The Visual Alarm will remain activated until the alarm condition is cleared.
- The ACO lamp on the faceplate will illuminate when the ACO is pushed, and will remain on until the fault is cleared. The alarms are self-clearing when the fault is cleared.

7.1.1 The Power LED

The Power LED is on whenever shelf power is on.

7.1.2 The MAJOR LED

The MAJOR LED comes on when the shelf major alarm threshold is exceeded. An alarm is predefined by the user to be either an alarm (fault) on 1, 2, 3, or 4 CTU cards. The alarm threshold is preset with switches located on the ACU circuit board. (See paragraph 4.2.1 of this Installation Note). The alarm can be also set for zero

7.1.3 The MINOR LED

The MINOR LED comes on whenever an alarm has been reported but when the preset shelf major alarm threshold is not met or exceeded. See Table 6 for a table of alarm states and conditions.

7.2 Contact Alarms

The Alarm Control Unit card has four normally open, Form C relays.

MAJOR - AUDIBLE MAJOR - VISUAL
MINOR - AUDIBLE MINOR - VISIBLE

Pins for externally wiring the relays are located on the backplane of the Multi-Service Shelf. When the MAJOR or MINOR LED comes on, both audible and visible relays for that alarm will close. Wiring instructions of Contact Alarms are included in the System Practice and Multi-Service Shelf INST NOTE.

8. Detail of all ACU LED Lamp Status and Alarm Relay Status

Table 5: ACU MOD H AD TABLE OF ALARM LED and RELAY STATES AND INDICATIONS

ALARM LED and RELAY STATES AND INDICATIONS								
<u>Condition of Card</u>	<u>LED Lamp Status</u>				<u>Major Relays</u>		<u>Minor Relays</u>	
	<u>PWR</u>	<u>MAJOR</u>	<u>MINOR</u>	<u>ACO</u>	<u>Audible</u>	<u>Visual</u>	<u>Audible</u>	<u>Visual</u>
Initial Plug-in & Normal Ops								
w/ Ext. Clock Present	ON	OFF	OFF	OFF	OPEN	OPEN	OPEN	OPEN
Press ACO	ON	ON	ON	ON	OPEN	OPEN	OPEN	OPEN
Without Ext. Clock	BLINK	OFF	OFF	OFF	OPEN	OPEN	OPEN	OPEN
Press ACO	BLINK	ON	ON	ON	OPEN	OPEN	OPEN	OPEN
Alarm Card Fuse Blows	OFF	ON	ON	OFF	CLO	CLO	CLO	CLO
Battery Supply Fails	OFF	OFF	OFF	OFF	OPEN	CLO	OPEN	CLO
Clock - Loss of Ext Clock And No CTU Alarms	BLINK	OFF	OFF	OFF	OPEN	OPEN	OPEN	OPEN
Clock - Loss of Ext Clock And CTU Minor	BLINK	OFF	ON	OFF	OPEN	OPEN	CLO	CLO
Clock - Loss of Ext Clock And CTU Major	BLINK	ON	OFF	OFF	CLO	CLO	OPEN	OPEN
CTU - Minor Alarm	ON	OFF	ON	OFF	OPEN	OPEN	CLO	CLO
Press & Release ACO	ON	OFF	ON	ON	OPEN	OPEN	OPEN	CLO
Trouble Clears	ON	OFF	OFF	OFF	OPEN	OPEN	OPEN	OPEN
CTU - Major Alarm	ON	ON	OFF	OFF	CLO	CLO	OPEN	OPEN
Press & Release ACO	ON	ON	OFF	ON	OPEN	CLO	OPEN	OPEN
Trouble Clears	ON	OFF	OFF	OFF	OPEN	OPEN	OPEN	OPEN

Installation Note

XCel Alarm Control Unit (ACU MOD H AD)



9. XCel Timing Reference Signal Specifications

Note: A timing reference is required for V.90 Analog POTS processing.

<p>Products:</p> <p>ACU MOD H AD: p/n 990249-A</p> <p>ACU MOD H CB: p/n 990249 <i>(discontinued)</i></p> <p>ACU MOD H: p.n 990113 <i>(discontinued)</i></p> <p>Composite Clock</p> <p>64 kHz AMI signal w/ no DC content w/ a 5/8 duty cycle w/ bipolr violation every 8 kHz</p> <p>Cabling to XCel Shelf</p> <p>Type of Cable CAT5 w/ sufficient twists to prevent noise pickup</p> <p>Length of Cable Between 25 and 200 feet</p> <p>Maximum Number of Shelves with a single daisy chained clock source:</p> <p>5 Shelves Max Terminate on last shelf</p> <p>Stratum Level</p> <p>Stratum 3 or better or SONET with 20 ppm accuracy</p> <p>DO NOT USE OR CONNECT:</p> <p>Stratum 4 or any clock that does not meet SONET requirements</p>	<p>Timing Sources</p> <p>BITS (Building Integrated Timing Supply clock)</p> <p>GPS –linked System clock (Ex: Symmetricom TimeSource 3000)</p> <p>DS1 signal converted to a composite clock.</p> <p>DO NOT USE a DS-1 signal carried within SONET (Jitter violates ANSI T1.101)</p> <p>Alternative Timing Source</p> <p>Basic Rate ISDN Line Sourced from a C.O. switch that is properly timed from a BITS clock or other Stratum 3 or better source.</p>
---	--

CONTACTING GODIGITAL

GoDigital Networks Corporation
41652 Boscell Road
Fremont, CA 94538

1-800-297-2424
1-510-979-2200
Fax 510-226-8785

Email

GoDigital Sales: sales@godigital.com
Technical Assistance: product.support@godigital.com