

1. Purpose and Products

This document provides detailed installation instructions for each CarrierNode plug-in module. This document is included with shipment of each CarrierNode Module and also is an attachment to the *XCel System Practice*. GoDigital recommends that one copy of the complete *System Practice* be kept in each Central Office that supports any XCel or CarrierNode Systems. This INST NOTE assumes that a CarrierNode Shelf was previously installed and is ready for installation of the plug-in CarrierNode Module and associated outside loop elements.

Figure 1-1: XCel-8 CarrierNode Module



1.1 Products

This Installation Note is relevant for the following GoDigital product:

Table 1-1

System / Product Name	Part #	Description
CN MOD 3X8P SELV 544 INT	990295	CarrierNode Plug-in Module with Selectable DSL Voltage supporting three each XCel-8 / GDSL-8 Systems

1.2 Related Products

This Installation Note also refers to the following related GoDigital products:

Table 1-2

System / Product Name	Part #	Description
SHLF CN 15-19-23 REAR ACCESS	990330	CarrierNode Shelf for 15, 19 or 23-inch Racks
KIT CN FRONT ACCESS	990337	CarrierNode Shelf Front Access Kit

2. Contents

Summary of Installation Steps	Item 3
CarrierNode Overview	Item 4
Planning and Engineering Information.....	Item 5
CarrierNode Step-By-Step Installation Instructions	Item 6
LED Status/Display Lamps	Item 7
CarrierNode Controls and Front Panel Access Points	Item 8
Alpha-Numeric LED Display, Messaging and Menu Navigation	Item 9
Troubleshooting	Item 10
Detailed CarrierNode Provisioning Switch Setting Options	Item 11
GoDigital APPROVED and NON-APPROVE Protector Types for CarrierNode	Item 12

Note: This equipment should be installed in accordance with the guidelines noted. Installation of this communications equipment is restricted to installations under the exclusive control of the communications utility, and located outdoors or in building spaces used exclusively for the installation in accordance with Section 90-2(b)(4) of the National Electrical code (NEC), ANSI/NFPA 70. Alternatively, for installations falling under the Scope of Article 800 of the NEW, the cable shall be properly installed per one of the allowed Exceptions to Section 800-50.

Installation Note

CN MOD 3X8P SELV 544 INT, XCel-8 CarrierNode Module

3. Summary of Installation Steps

- Step 1. Verify that the CarrierNode Shelf has been properly installed and grounded**
- Step 2. Verify that XCel loops have been designed in accordance with the Configur8r™ design tool,**
- Step 3. Unpack and inspect the CarrierNode Module.**
- Step 4. Verify and/or adjust the CarrierNode Module provisioning settings: Switches SW1 – SW10.**
- Step 5. Verify or install the proper MDF or station-type protectors.**
- Step 6. Apply –48 Vdc power to the CarrierNode Shelf.**
- Step 7. Install / Verify DS1 is Active from the Switch to the CarrierNode Shelf.**
- Step 8. Insert the CarrierNode Module into the CarrierNode Shelf.**
- Step 9. Confirm CarrierNode Settings**
- Step 10. Turn-up and Link-up the XCel Loops**
- Step 11. Confirm/verify proper loop operation at CarrierNode and at the remote elements.**

4. CarrierNode Overview

The CarrierNode Module is a plug-in electronics module used in conjunction with the CarrierNode Shelf. It plugs into the Shelf and interfaces with the XCel repeaters and remote terminal units comprising a System. The XCel-8 CarrierNode supports three (3) separate XCel-8 loops. These loops operate in the same manner as previously deployed XCel-8 loops delivering eight high quality POTS lines from small line powered remote terminals.

4.1 Functional Description

The XCel-8 CarrierNode, multiplexes twenty-four (24) POTS-based DS0s and transmits them over the three (3) each, single pair XCel-8 loops. DS0s are “hardwired” with #1-#8 assigned to XCel-8 System One, #9-#16 to System two, and #17-#24 to System three. CarrierNode also places line powering on the pairs to OSP elements. In the OSP elements the XCel-8 loops are repeated and the DS0s are de-multiplexed and reconverted to analog POTS signals for dropping to subscribers.

4.1.1 A detailed description of CarrierNode displays and operating switches and buttons is provided in **Sections 7, 8 and 9** of this INST NOTE.

4.1.2 A system diagram of the CarrierNode XCel-8 is provided in below.

Figure 4-1 XCel-8 CarrierNode System

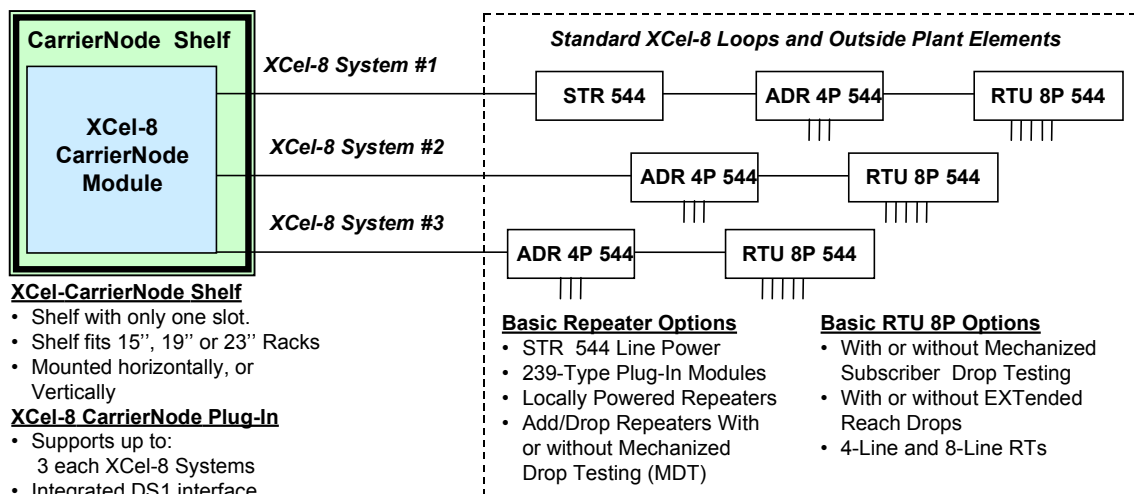

4.1.3 A block diagram of the CarrierNode XCel-8 plug-in module is provided on the following page.

Figure 4-2: CarrierNode Plug-in Module Functional Block Diagram

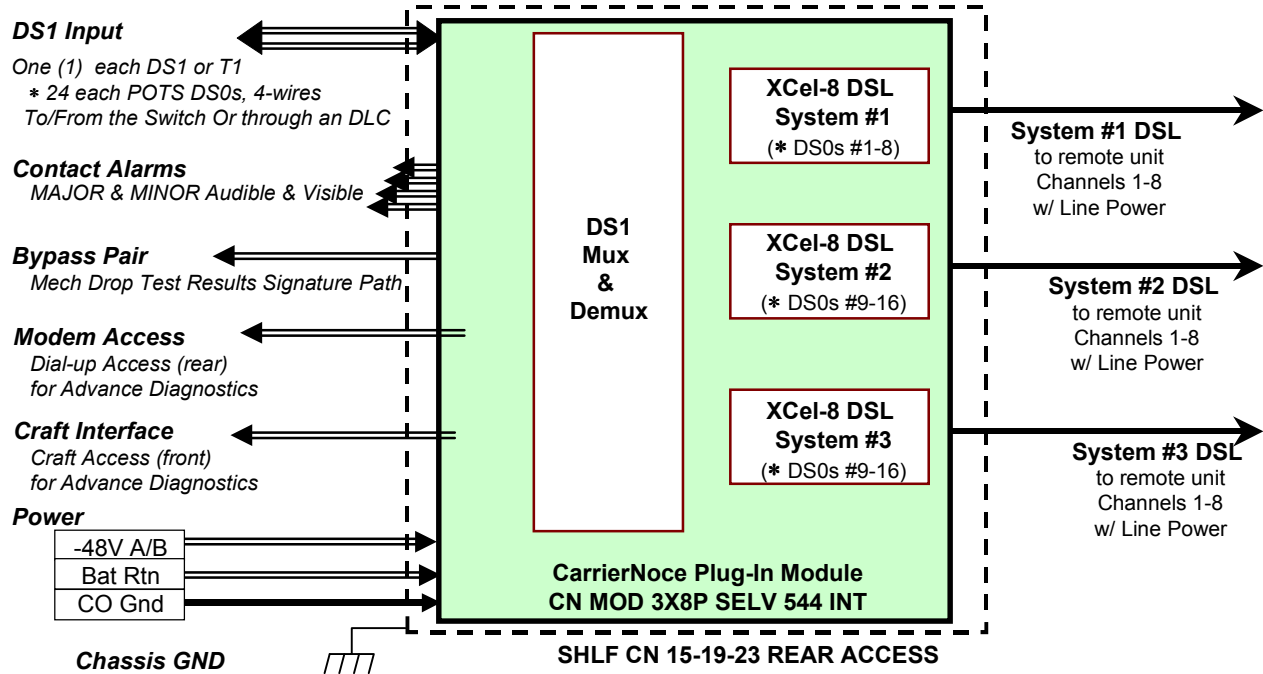

- 4.2 Differences and characteristics of the XCel-8 CarrierNode compared to the standard XCel-8 System:
- The XCel-8 CarrierNode can serve as an alternative to the XCel-8 in the XCel Multi-Service Shelf for deployment when space is not available for the larger shelf.
 - One CarrierNode plug-in supports up to three XCel-8 System loops while a plug-in XCel-8 CTU for the XCel Shelf supports one XCel-8 System loop.
 - CarrierNode with the XCel-8 plug-in module has an integrated (DS1/DSX-1) interface with channelized POTS-based DS0s upstream to the switch. The XCel-8 System CTUs in the XCel Shelf have eight each analog POTS interfaces to the switch.
 - The XCel-8 CarrierNode serves/hosts the same loop options and elements available with the current XCel-8 System including support for various repeaters (STRs and ADRs) and remote terminals (RTUs and TADs).
 - The XCel-8 CarrierNode plug-in Module has options that are provisioned during installation by setting switches on the card:
 - Option for DSL line-powering voltages of either ± 130 (factory default) or ± 190 Vdc.
 - Option for XCel Standard Loop Testing or full Mechanized Drop Testing (MDT) (factory default).
 - Option for types of loop test reporting signatures:
 - Standard Loop Test Signature Options: MLT or 4Tel,
 - Mechanized Drop Test Signature Options: GR-909 (factory default) or TR-398.
 - Options for setting the MAJOR Alarm THRESHOLD levels.
 - CarrierNode has alpha-numeric display functionality. The XCel-8 CTUs use colored LEDs only.
 - CarrierNode provides access for local monitoring of POTS DS0s at the CarrierNode shelf.
 - The XCel-8 CarrierNode can manually (locally) initiate a Loop Test and (if MDT OSP elements are used) a Drop Test. CarrierNode also displays the results locally on the front panel display.
 - CarrierNode can be accessed with GoDigital's Advanced Diagnostic PC-based GUI application software, either with a front access craft interface port, or via a modem dial up line wired to the backplane.

Installation Note

CN MOD 3X8P SELV 544 INT, XCel-8 CarrierNode Module



5. Planning and Engineering Information

5.1 CarrierNode Shelf Planning and Engineering

See **INST NOTE 010212** for detailed information on pre-planning, engineering, and proper installation of the CarrierNode Shelf. INST NOTE 010212 includes the following:

- CarrierNode Shelf Step by Step Installation Instructions.
 - Option A: Installed REAR ACCESS is Available: (Office-type installation)
 - Option B: NO REAR ACCESS is available but cabling directly to rear of shelf is desired
 - Option C: Using CarrierNode’s optional FRONT ACCESS KIT when NO REAR ACCESS is available
- Mounting Options for the CarrierNode Shelf
 - Rack mounting in 23-inch, 19-inch or 15-inch racks
 - Vertical mounting beside a rack and Wall mounting
- Cooling and Heat Dissipation
- Input Power to CarrierNode
- Fusing and Current
- Shelf Cabling
- Cable and Wire Connections to the CarrierNode
- Detail of CarrierNode Shelf Grounding Procedures and Options
- Rack Spacing

5.2 XCel-8 System and XCel-8 CarrierNode Module Planning and Engineering.

5.2.1 XCel-8 CarrierNode Loops MUST be designed using the GoDigital XCel-8 Configu8r.

5.2.2 The XCel-8 CarrierNode plug-in module is hot-loadable.

5.2.3 The CarrierNode plug-in module includes alarm card functionality and no separate card is needed.

5.2.4 Contact Alarm connections are wire wrap pairs on the backplane of the CarrierNode Shelf or on the optional Front Access Kit. CarrierNode provides the following contact alarms:

- MAJOR – VISUAL – MAJOR – AUDIBLE
- MINOR – VISUAL – MINOR – AUDIBLE

5.2.5 No separate timing inputs are required for XCel-8 CarrierNode. Timing is derived from the DS1.

5.2.6 No special processing is required to support V.90 POTS modem performance with the CarrierNode’s integrated interface. As long as the XCel-8 CarrierNode’s DS0s remain in digital format upstream to the switch, the XCel-8 loops will support V.90 modem speeds on their drops.

5.2.7 Interoperability and Provisioning for Class 5 Switches, DLCs and MUXes.

5.2.7.1 Class 5 Switch Interfaces, Interoperability and Provisioning

XCel-8 CarrierNode supports two standard DS1 interface options upstream.

- TR-008 (SLC96) – D4 (SF)

XCel-8 CarrierNode has been tested during trials with the following switches and interfaces.

Table 5.2-1: Class 5 Switch TR-008 Interoperability and Switch Provisioning

	Lucent Technologies	NORTEL Networks	SIEMENS	
Switch Type	5ESS	DMS-100	EWSD	DCO
Switch Interface Mode	TR-008	TR-008	TR-008	TR-008
Switch Provisioning	<ul style="list-style-type: none"> • SLC96 Framing • TR-008, Mode 1 • Link A / Shelf A 	<ul style="list-style-type: none"> • SLC96 Framing • TR-008, Mode 1 • Link A / Shelf A 	<ul style="list-style-type: none"> • SLC96 Framing • TR-008, Mode 1 • Shelf A 	<ul style="list-style-type: none"> • SLC96 Framing • TR-008, Mode 1 • Link A (Span A)
Switch Interface To CarrierNode	<ul style="list-style-type: none"> • TN1670 Loop Side Interface Pack 	<ul style="list-style-type: none"> • NT6X85AC 	<ul style="list-style-type: none"> • SLC1A Line card 	<ul style="list-style-type: none"> • RTIF2 Span Card p/n 817643-526 • RTF1 Controller Card p/n 817642-526

5.2.7.2 DLC Interoperability and DLC Provisioning

XCel-8 CarrierNode has been tested during initial trials with the following digital loop carriers and associated DLC provisioning settings.

Table 5.2-2: DLC Interoperability and DLC Provisioning

	Alcatel	AFC
DLC Type	LITESPAN 2000	UMC 1000
Switch Interface Mode	TR-008	TR-008
Switch Provisioning	<ul style="list-style-type: none"> • TR-008, Mode 1, Shelf/Link A 	<ul style="list-style-type: none"> • D4 (SF) • TR-008, Mode 1, Shelf/Link A, or • AFC UMC 1000 Proprietary
DLC Interface To CarrierNode	<ul style="list-style-type: none"> • DS1U Line Card 	<ul style="list-style-type: none"> • T1AX Line Card
DLC Provisioning	<ul style="list-style-type: none"> • Transparent / Pass-Thru 	<ul style="list-style-type: none"> • Transparent / Pass-Thru
NOTE: Transparent Mode transports the T1 intact from the CarrierNode to the Switch with out Signaling conversion or data link termination		

5.2.7.3 Other / MUX Interoperability and Provisioning

XCel-8 CarrierNode has been tested during initial trials with the following MUX and associated MUX provisioning settings.

Table 5.2-3 Other / MUX Interoperability and Provisioning

	Fujitsu	NORTEL Networks	CarrierAccess
Equipment Type	FLM 150 Fiber MUX	DMS SuperNode SCM-11A, or Expanded SCM-100A (ESMA)	Access Navigator
Switch Interface Mode	TR-008	TR-008 (Switch: DMS -100)	GR-303 (via concentrator)
Switch Provisioning	<ul style="list-style-type: none"> • TR-008, Mode 1, Shelf/Link A 	<ul style="list-style-type: none"> • TR-008 (SCM-100A or ESMA), Mode 1, Link A 	GR-303 per AccessNavigator
Interfaces to CarrierNode	<ul style="list-style-type: none"> • DS1 Line Card 	<ul style="list-style-type: none"> • NTMX81AA/87AA Line Card on the main ESMA or Extension Shelf 	<ul style="list-style-type: none"> • One port of QUAD T1
Equipment Provisioning	<ul style="list-style-type: none"> • Transparent / Pass-Thru 	<ul style="list-style-type: none"> • Transparent / Pass-Thru 	<ul style="list-style-type: none"> • SLC96 Framing • TR-008, Mode 1, Shelf A
NOTE: Transparent Mode transports the T1 intact from the CarrierNode to the Switch with out Signaling conversion or data link termination			

5.2.7.4 CarrierNode in the GR-303 Environment

XCel-8 CarrierNode does not provide a direct GR-303 interface to a GR-303 Interface Group. CarrierNode only supports twenty-four (24) DS0s, which is well below the normal GR-303 interface group size. However, CarrierNode payload can be aggregated/concentrated within a GR-303 concentration platform which may be separate equipment such as the CarrierAccess “AccessNode” or may be a DLC that is capable of concentrating CarrierNode DS0s into it’s own interface groups. Call GoDigital for the most current status on interoperability testing in the GR-303 environment.

5.3 Pre-Planning CarrierNode Settings

Prior to installing/deploying the XCel-8 CarrierNode in a particular application it can be helpful to determine which options are desired so that the CarrierNode module switches can be quickly set for each application. These settings can be made prior to taking the CarrierNode Module to the shelf location. For Actual setting of switches and options, see *paragraph 6.4, STEP 4*, in this INST NOTE.

Installation Note

CN MOD 3X8P SELV 544 INT, XCel-8 CarrierNode Module



Table 5.3-1

XCel-8 CarrierNode Module Provisioning Options and Defaults (●)

	Function	Option
SW1	Framing	SF (D4) (Superframe) ●
		ESF (Extended Superframe)
	SLC 96 Mode	T1
		TR-008 / SLC 96 ●
	GR-303 Mode	T1 ●
		GR-303
	Coding	AMI ●
		B8ZS
	LBO (Line Build Out)	0 dB & 0 - 133 ft DSX ●
		133 - 266 ft DSX
266 - 399 ft DSX		
399 - 533 ft DSX		
533 - 655 ft DSX		
-7.5 dB		
-15 dB		
-22.5 dB		

	Function	Option
SW2	Timing	Loop Timed ●
		Internal Timed
	In-Band Loop Detect	Loop Detect Disabled ●
		Loop Detect Enabled
	FDL Loop Detect (ESF only)	FDL Disabled ●
FDL Enabled		

	Function	Option
SW3	Determines the number of DSL's in an Alarm Condition that trigger a MAJOR Alarm	DSL Alarms will NOT trigger a MAJOR Alarm ●
		Two or More DSL Alarms trigger a MAJOR Alarm
		One or More DSL Alarms trigger a MAJOR Alarm
		Three DSL Alarms trigger a MAJOR Alarm
T1 Near End Alarm is Reported as MAJOR Alarm by CarrierNode	T1 Near End Alarm will NOT trigger CN MAJOR Alarm ●	
	T1 Near End Alarm triggers CN MAJOR Alarm	
Determines how GoDigital Advanced Diagnostic System will remotely access the CarrierNode Shelf. Either: • a separate pair used for modem access to Shelf, or • DS0 #24 dedicated (in the DS1) for modem access.	Rear Panel Modem Access ●	
	T1 Channel (DS0 #24) Modem Access	

	Function	Option
SW4, SW5, SW6 & SW7	Type of Loop & Drop Testing to be performed in the XCel-8 Systems	Standard Loop Test with 4TEL Signatures
		Standard Loop Test with MLT Signatures
		Mechanized Loop & Drop Test (MDT) with GR-909 Signatures ●
		Mechanized Loop & Drop Test (MDT) with TR-398 Signatures

SW8, SW9 & SW10	Function	Option
	Voltage For XCel-8 Line Powering	± 130 Vdc ●
		± 190 Vdc

6. Installation

WARNING

These installation procedures assume that the CarrierNode Shelf was previously install in accordance with GoDigital **INST NOTE 010212**, including proper connections to -48 Vdc power supplies, grounding and circuit protection. Do not proceed with installation of this plug-in electronics module until the CarrierNode Shelf has properly installed and configured. Failure to properly install the CarrierNode Shelf in accordance with INST NOTE 010212 can result in unreliable XCel System performance, equipment damage and inadequate safety conditions or injury.

6.1 STEP 1: Verify that the CarrierNode Shelf has been properly installed and grounded

CAUTION: The CarrierNode Shelf MUST BE GROUNDED in accordance with shelf installation instructions and local practices by attaching a #14 AWG conductor or larger between the CO Ground screw on the rear of the Shelf and to CO ground or earth ground. Shelf to ground resistance should be a maximum 25 ohms. Failure to properly ground the shelf can result in equipment damage during normal turn-up and operation. In addition, the CarrierNode will be susceptible to lightning surge damage without a proper grounding.

- 6.2 STEP 2: Verify that XCel loops have been designed in accordance with the Configu8r™ design tool.**
Separate Configu8rs are available for different system types. Improper system design can result in difficulty in link-up, unreliable or erratic loop performance and difficulty in troubleshooting.
- 6.3 STEP 3: Unpack and inspect the CarrierNode Module.**
Make a quick visual check of the CarrierNode Module plug-in card for any shipping damage.
- 6.4 STEP 4: Verify and/or adjust the CarrierNode Module provisioning settings.**
Below is a drawing showing the locations of SW1 through SW7 on the XCel-8 CarrierNode plug-in card. On the pages following the drawing, *Paragraphs 6.4.1 through 6.4.5* identify the typical switch setting templates by major telco. Verification of switch settings is required up prior to insertion in the CarrierNode Shelf for proper board set-up and CarrierNode operation. Detailed individual switch setting options are in *Section 11*.

Figure 6.4-1: Location of Switches on the XCel-8 CarrierNode Module

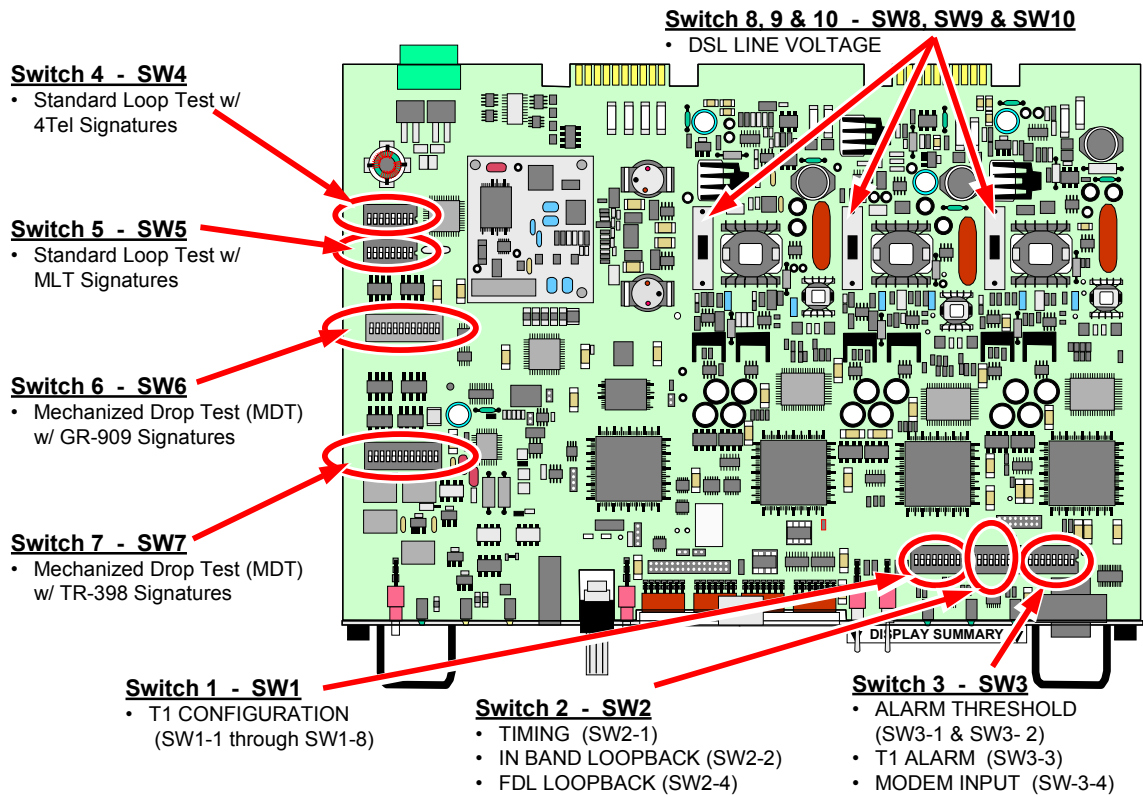

6.4.1 Detailed Switch Setting Options

Section 11 of this INST NOTE provides DETAILED setting options for CarrierNode switches.

6.4.2 CarrierNode Provisioning Switch Setting Profiles by Customer

This section provides templates for XCel-8 CarrierNode switch settings in accordance with the basic options that are normally used by the specific customer or customer groups. This section has the following typical templates:

- Verizon West and Independent Telcos.....**Para. 6.4.2.1**
- Verizon East**Para. 6.4.2.2**
- BellSouth**Para. 6.4.2.3**
- Qwest and SBC with MDT Systems**Para. 6.4.2.4**
- Qwest Only Systems With Standard Loop Test Only.....**Para. 6.4.2.5**

Installation Note

CN MOD 3X8P SELV 544 INT, XCel-8 CarrierNode Module



6.4.2.1 Verizon West and Independent Telco CarrierNode Switch Setting Template

- XCel-8 Loops
- Standard Loop Test
- ±190Vdc Line Power
- w/4Tel Signatures

Table 6.4.2-1: Typical Switch Settings for Verizon West and for Most Independent Telcos

SW Mod. #	Switch Number "N" (SWx-N) (N=1-8)								Comments				
	1	2	3	4	5	6	7	8					
SW1-N	OFF ●	ON ●	OFF ●						No changes from Defaults. TR-008 / SLC96 Mode, AMI, LBO: 0-133 ft, Loop Back Norm.				
SW2-N	OFF ●								No changes from Defaults. Loop Timed, Loop Detect Disabled				
	1	2	3	4	5	6	7	8					
SW3-N	ON ●		OFF ●						No changes from Defaults. 3 DSL Alarms will trigger MAJOR. T1 Near End Alarm does NOT trigger MAJOR. Modem Access via rear panel with dedicated pair.				
SW4-N	ON								Change ALL Switches SW4-1 To SW4-8 to ON For Standard Loop Test with 4TEL Signatures				
SW5-N	OFF ●								No changes from Defaults. Standard Loop Test w/ 4TEL Signatures				
	Switch Number "N" (SWx-N) (N=1-12)												
	1	2	3	4	5	6	7	8	9	10	11	12	
SW6-N	OFF								Change ALL Switches SW6-1 to SW6-12 to OFF For Standard Loop Test with 4TEL Signatures				
SW7-N	OFF ●								No changes from Defaults. For Standard Loop Test with 4TEL Signatures				
	Only One Switch per SWx												
SW8	190								Change Switch SW8 to 190				
SW9	190								Change Switch SW9 to 190				
SW10	190								Change Switch SW10 to 190				

6.4.2.2 Verizon East CarrierNode Switch Setting Template

- XCel-8 Loops
- Mechanize Drop Test (MDT)
- ±130Vdc Line Power
- w/ TR-398 Signatures

Table 6.4.2-2: Typical Switch Settings for Verizon East ONLY

SW Mod. #	Switch Number "N" (SWx-N) (N=1-8)								Comments				
	1	2	3	4	5	6	7	8					
SW1-N	OFF ●	ON ●	OFF ●						No changes from Defaults. TR-008 / SLC96 Mode, AMI, LBO: 0-133 ft, Loop Back Norm.				
SW2-N	All OFF ●								No changes from Defaults. Loop Timed, Loop Detect Disabled				
	1	2	3	4	5	6	7	8					
SW3-N	ON ●		OFF ●						No changes from Defaults. 3 DSL Alarms will trigger MAJOR. T1 Near End Alarm does NOT trigger MAJOR. Modem Access via rear panel with dedicated pair.				
SW4-N	All OFF ●								No changes from Defaults for MDT Test & TR-398 Signatures.				
SW5-N	All OFF ●								No changes from Defaults for MDT Test & TR-398 Signatures.				
	Switch Number "N" (SWx-N) (N=1-12)												
	1	2	3	4	5	6	7	8	9	10	11	12	
SW6-N	All OFF								Change ALL Switches SW6-1 to SW6-12 to OFF For MDT Loop / Drop Test & TR-398 Signatures.				
SW7-N	All ON								Change ALL Switches SW7-1 to SW7-12 to ON For MDT Loop / Drop Test & TR-398 Signatures.				
	Only One Switch per SWx												
SW8	130 ●								No changes from Defaults. ±130 Vdc Line Power				
SW9	130 ●								No changes from Defaults. ±130 Vdc Line Power				
SW10	130 ●								No changes from Defaults. ±130 Vdc Line Power				

6.4.2.3 BellSouth CarrierNode Switch Setting Template

- XCel-8 Loops
- Mechanize Drop Test (MDT)
- ±190Vdc Line Power
- w/ GR-909 Signatures

Table 6.4.2-3: Typical Switch Settings for BellSouth

SW Mod. #	Switch Number "N" (SWx-N) (N=1-8)								Comments				
	1	2	3	4	5	6	7	8					
SW1-N	OFF ●	ON ●	OFF ●							No changes from Defaults. TR-008 / SLC96 Mode, AMI, LBO: 0-133 ft, Loop Back Norm.			
SW2-N	OFF ●									No changes from Defaults. Loop Timed, Loop Detect Disabled			
	1	2	3	4	5	6	7	8					
SW3-N	ON ●		OFF ●							No changes from Defaults. 3 DSL Alarms will trigger MAJOR. T1 Near End Alarm does NOT trigger MAJOR. Modem Access via rear panel with dedicated pair.			
SW4-N	All OFF ●								No changes from Defaults for MDT Test & GR-909 Signatures.				
SW5-N	All OFF ●								No changes from Defaults for MDT Test & GR-909 Signatures.				
	Switch Number "N" (SWx-N) (N=1-12)												
	1	2	3	4	5	6	7	8	9	10	11	12	
SW6-N	All ON ●											No changes from Defaults for MDT Test & GR-909 Signatures.	
SW7-N	All OFF ●											No changes from Defaults for MDT Test & GR-909 Signatures.	
	Only One Switch per SWx												
SW8	190											Change Switch SW8 to 190	
SW9	190											Change Switch SW9 to 190	
SW10	190											Change Switch SW10 to 190	

6.4.2.4 Qwest and SBC with MDT Systems CarrierNode Switch Setting Template

- XCel-8 Loops
- Mechanize Drop Test (MDT)
- ±130Vdc Line Power
- w/ GR-909 Signatures

Table 6.4.2-4: Typical Switch Settings for Qwest and SBC on XCel-8 Systems with MDT

SW Mod. #	Switch Number "N" (SWx-N) (N=1-8)								Comments				
	1	2	3	4	5	6	7	8					
SW1-N	OFF ●	ON ●	OFF ●							No changes from Defaults. TR-008 / SLC96 Mode, AMI, LBO: 0-133 ft, Loop Back Norm.			
SW2-N	All OFF ●									No changes from Defaults. Loop Timed, Loop Detect Disabled			
	1	2	3	4	5	6	7	8					
SW3-N	ON ●		OFF ●							No changes from Defaults. 3 DSL Alarms will trigger MAJOR. T1 Near End Alarm does NOT trigger MAJOR. Modem Access via rear panel with dedicated pair.			
SW4-N	All OFF ●								No changes from Defaults for MDT Test & GR-909 Signatures				
SW5-N	All OFF ●								No changes from Defaults for MDT Test & GR-909 Signatures				
	Switch Number "N" (SWx-N) (N=1-12)												
	1	2	3	4	5	6	7	8	9	10	11	12	
SW6-N	All ON ●											No changes from Defaults for MDT Test & GR-909 Signatures	
SW7-N	All OFF ●											No changes from Defaults for MDT Test & GR-909 Signatures	
	Only One Switch per SWx												
SW8	130 ●											No changes from Defaults. ±130 Vdc Line Power	
SW9	130 ●											No changes from Defaults. ±130 Vdc Line Power	
SW10	130 ●											No changes from Defaults. ±130 Vdc Line Power	

Installation Note

CN MOD 3X8P SELV 544 INT, XCel-8 CarrierNode Module



6.4.2.5 Qwest Only Systems With Standard Loop Test Only Switch Setting Template

- XCel-8 Loops, • Standard Loop Test
- ±130Vdc Line Power, • w/ MLT Signatures

Table 6.4.2-5: Typical Switch Settings for Qwest on XCel-8 Systems with Standard Loop Test

SW Mod. #	Switch Number "N" (SWx-N) (N=1-8)								Comments			
	1	2	3	4	5	6	7	8				
SW1-N	OFF ●	ON ●	OFF ●							No changes from Defaults. TR-008 / SLC96 Mode, AMI, LBO: 0-133 ft, Loop Back Norm.		
SW2-N	All OFF ●								No changes from Defaults. Loop Timed, Loop Detect Disabled			
	1	2	3	4	5	6	7	8				
SW3-N	ON ●	OFF ●							No changes from Defaults. 3 DSL Alarms will trigger MAJOR. T1 Near End Alarm does NOT trigger MAJOR. Modem Access via rear panel with dedicated pair.			
SW4-N	OFF ●								No changes from Defaults For Standard Loop Test with MLT Signatures			
SW5-N	All ON								Change ALL Switches SW5-1 to SW5-8 to ON For Standard Loop Test with MLT Signatures			
	Switch Number "N" (SWx-N) (N=1-12)											
	1	2	3	4	5	6	7	8	9	10	11	12
SW6-N	All OFF								Change ALL Switches SW6-1 to SW6-12 to OFF For Standard Loop Test with MLT Signatures			
SW7-N	All OFF ●								No changes from Defaults For Standard Loop Test with MLT Signatures			
	Only One Switch per SWx											
SW8	130 ●								No changes from Defaults. ±130 Vdc Line Power			
SW9	130 ●								No changes from Defaults. ±130 Vdc Line Power			
SW10	130 ●								No changes from Defaults. ±130 Vdc Line Power			

6.5 Verify or install the proper MDF or station-type protectors. See [Section 12](#) for approved protectors.

CAUTION: Replace any existing protectors on the DSL pairs with GoDigital Approved protectors ONLY. See [Section 12](#) of this Installation Note. Failure to do this will result in inadvertent protector firing and can cause system outages and possible equipment damage.

6.6 Apply -48Vdc power to the CarrierNode Shelf.

Note: Power can be applied either prior to or after the CarrierNode Module is inserted into the Shelf.

6.7 Install / Verify DS1 is Active from the Switch to the CarrierNode Shelf

6.7.1 The DS1 should be provisioned and active prior to installing the CarrierNode Module in the Shelf.

Note: CarrierNode must link with and derive timing from the DS1. If the DS1 is active when the CarrierNode is installed, the link up will only take a few seconds. If the DS1 is not active when the CarrierNode Module is installed, link up between the CarrierNode and the DS1 may take an hour or more, because already operating loops will have adjust their timing to the DS1.

6.8 Insert the CarrierNode Module into the CarrierNode Shelf

- 6.8.1 Carefully insert the CarrierNode Module into the left and right Shelf card guides.
- 6.8.2 Push the Module in by the faceplate until it seats firmly in the connector of the shelf backplane.
- 6.8.3 Use the left and right thumbscrews on the faceplate to seat and secure the Module in the Shelf.
- 6.8.4 The XCel-8 loops automatically initiate their individual linking sequences with XCel-8 OSP units.

NOTE: Upon initial insertion and power up, and until the XCel-8 loop links are established for the first time, no alarms will be indicated.

6.9 Confirm CarrierNode Settings

The basic option settings made on CarrierNode Module card can be verified using the two Display Control switches on the front panel of the installed CarrierNode. **Table 9.3-1, Block 6**, describes the menus and switch control sequences needed to view the CarrierNode provisioning switch settings.

6.10 Turn Up and Link Up the XCel Loops

6.10.1 Upon insertion the CarrierNode will:

- Initiate linking with the incoming DS1.

Note: CarrierNode must link with and derive timing from the DS1. If the DS1 is active when the CarrierNode is installed, the link up will only take a few seconds. If the DS1 is not active when the CarrierNode Module is installed, link up between the CarrierNode and the DS1 may take an hour or more, because already operating loops will have adjust their timing to the DS1.

- Power up the DSL pairs with DC voltage. Voltage levels on each DSL will be either +/-190Vdc, +/-130Vdc depending on the specific settings made on the CarrierNode Module prior to insertion.
- Immediately begin a search cycle to automatically detect and link with the first Repeater or Remote Terminal on each of the three XCel-8 DSLs.

6.10.2 If on one or more the three loops, CarrierNode does not detect a repeater or RTU after 5 minutes of trying, that loop will go into a power down state and remove power from the loop. CarrierNode will automatically reattempt to link on that loop with a repeater or RTU after one minute in the power down state. During the pre-linking phase, the DSL LED for that loop will fast blink (once per second) and the MINOR LED will be OFF.

6.10.3 If CarrierNode senses a shorted DSL or if it has exhausted its attempts to link, the DSL LED will go into a slow blink (once every two seconds) for one minute. CarrierNode will re-attempt linking after this minute of power down.

6.10.4 CarrierNode links with the first outside plant element on each loop and then each subsequent element continues to link up in turn down the line. Allow up to five minutes for all sections in a loop to link before beginning any troubleshooting.

6.11 Confirm/verify proper loop operation at CarrierNode and at the remote elements

7. LED Status / Display Lamps and Alarms

7.1 XCel-8 CarrierNode LED Status / Display Lamps

There are twelve LED lamps used to display information or states during operation, plus over 16-digit alphanumeric display. The following figure and table detail the display information

Figure 7-1: CarrierNode LEDs and Display

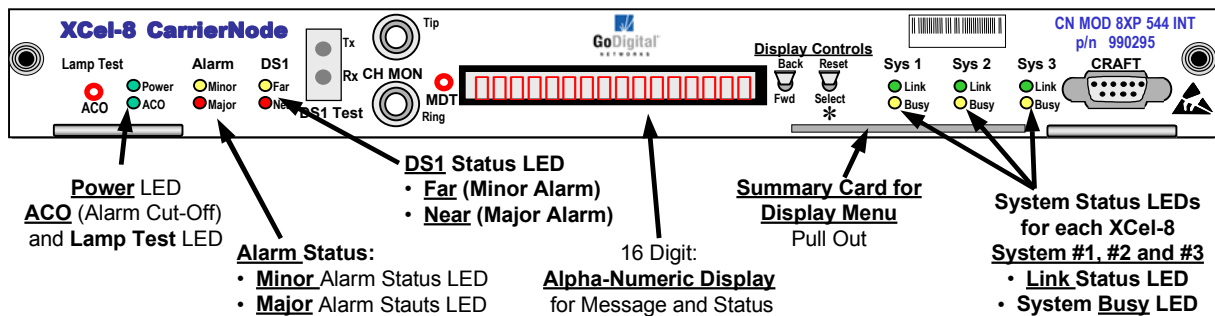

Installation Note

CN MOD 3X8P SELV 544 INT, XCel-8 CarrierNode Module



Table 7.1-1: CarrierNode LED and Display Descriptions

LED	State & Color	Description
Power	ON STEADY - Green	Shelf and Module are receiving proper -48 Vdc power.
	OFF	Shelf and Module are NOT receiving proper power.
ACO	ON STEADY - Green	Alarm Cut-Off has been triggered, canceling previously reported AUDIBLE (MAJOR and MINOR) alarm reporting.
	OFF	Alarm Cut-Off has not been triggered to cancel AUDIBLE alarms.
Alarm - Minor	ON STEADY - Yellow	<ul style="list-style-type: none"> One (or more) of the XCel Systems is in an alarm condition indicating that it has linked once but has now dropped link, or The DS1 Far or Near Alarm has been triggered
	OFF	<ul style="list-style-type: none"> No XCel Systems are in an alarm condition, and The DS1 is not in a Near or Far alarm condition.
Alarm - Major	ON STEADY - Red	One of the MAJOR Alarm Thresholds have been exceeded. Either: <ul style="list-style-type: none"> The number of XCel Systems in Alarm state exceeds the THRESHOLD (See paragraph 6.4.3.1), or The DS1 Near end alarm has been activated and CarrierNode settings require reporting as a Major Alarm (See paragraph 6.4.3.2).
	OFF	The Major Alarm Thresholds have NOT been exceeded.
DS1 - Far	ON STEADY - Yellow	One or more of the following is detected on the T1: <ul style="list-style-type: none"> Loss of Sync detected on incoming T1 Loss of Signal detected on incoming T1 AIS received on incoming T1 Yellow alarm received on T1
	OFF	None of the above conditions are detected on the T1
DS1 - Near	ON STEADY - Red	Sending AIS: Valid only when not using DS0 #24 for remote access, otherwise AIS is sent when all of CarrierNode's Loops/DSLs have dropped link
	OFF	Not sending AIS
DISPLAY SUMMARY	Pull-Out Card	Details the top layer of the Alpha-Numeric Display menu enabling craft person to orient themselves to menu navigation with the Display Controls.
Sys 1, Sys 2 or Sys 3 Link	STEADY ON - Green	XCel System "N" is linked with first element
	FAST BLINK - Green (~ 2 blinks per sec.)	XCel System "N" is attempting to link with first XCel OSP element..
	STEADY ON - Green	XCel System "N" is linked with first element.
	SLOW BLINK - Green (~ 1 blink per sec.)	XCel System "N" has detected a short and is waiting to restart.
	OFF	XCel System "N" is not attempting to link and is in a power down state.
Sys 1, Sys 2 or Sys 3 Busy	STEADY ON - Yellow	XCel System "N" has one or more lines with active POTS traffic.
	OFF	XCel System "N" is not indicating any busy lines

7.2 XCel-8 CarrierNode Alarms

7.2.1 Contact Alarms

The XCel-8 CarrierNode supports up to four normally open, Form C relays.

MAJOR – AUDIBLE MAJOR – VISUAL
MINOR – AUDIBLE MINOR – VISIBLE

- Pins for externally wiring the relays are located on the backplane of the CarrierNode Shelf, or (optionally) on the front of the CarrierNode Front Access Kit.
- When the CarrierNode MAJOR or MINOR LED comes on, audible and visible alarm relays close.
- See wiring instructions for Contact Alarms included in the System Practice and Shelf INST NOTE.
- Pressing the Alarm Cutoff (ACO) button on the CarrierNode faceplate opens the Audible Alarm relay and light the ACO LED. This LED stays illuminated until the MAJOR or MINOR alarm is cleared.
- Visual Alarms will remain activated until the alarm condition is cleared.
- All alarms are self-clearing when the fault is cleared.

7.2.2 Detail of CarrierNode Alarm LED Lamp and Alarm Relay States

Table 7.2-1: Alarm LED Lamp and Alarm Relay States

CarrierNode State	LED Lamp Status				Major Relays		Minor Relays	
	PWR	MAJOR	MINOR	ACO	Audible	Visual	Audible	Visual
Initial Plug-in & Normal Ops	ON	OFF	OFF	OFF	OPEN	OPEN	OPEN	OPEN
Press ACO	ON	ON	ON	ON	OPEN	OPEN	OPEN	OPEN
CarrierNode - Minor Alarm	ON	OFF	ON	OFF	OPEN	OPEN	CLO	CLO
Press & Release ACO	ON	OFF	ON	ON	OPEN	OPEN	OPEN	CLO
Trouble Clears	ON	OFF	OFF	OFF	OPEN	OPEN	OPEN	OPEN
CarrierNode - Major Alarm	ON	ON	OFF	OFF	CLO	CLO	OPEN	OPEN
Press & Release ACO	ON	ON	OFF	ON	OPEN	CLO	OPEN	OPEN
Trouble Clears	ON	OFF	OFF	OFF	OPEN	OPEN	OPEN	OPEN
CarrierNode Fuse Blows / -48Vdc Fails	OFF	OFF	OFF	OFF	CLO	CLO	CLO	CLO

8. CarrierNode Controls and Front Panel Access Points

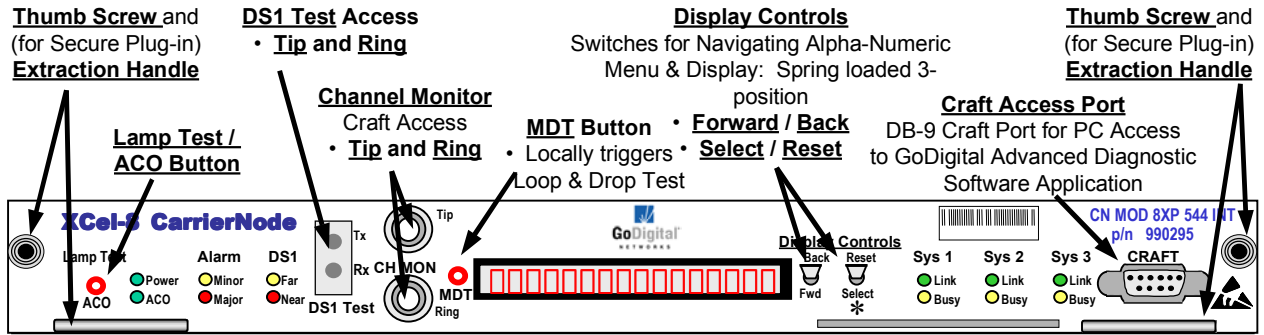

Figure 8-1: CarrierNode Controls and Front Panel Access Points

Table 8-1: CarrierNode Front Panel Controls and Access Points

Item	Operation and Description
Thumb Screws (2 each)	Thumb Screws to secure the CarrierNode Module in the Shelf. CarrierNode must be firmly seated into the back of the shelf for connections to allow for proper operation.
Extraction Handles (2 each)	Extraction Handles enable easy removal of the CarrierNode Module from the Shelf. Pulling on the Extraction Handles simultaneously extracts the Module without stressing the shelf or connections.
Lamp Test / ACO (Button)	<ul style="list-style-type: none"> Tests all LEDs and all of the digits in the Alpha-Numeric Display Opens the Alarm Cut-Off relay for both the MAJOR and MINOR Audible contact alarms
DS1 Test Tx & Rx	A test access point for monitoring the incoming DS1 with a DS1 test set.
Channel Monitor Tip & Ring	POTS test access point to monitor POTS line traffic on any of the 24 POTS lines served by CarrierNode. <ul style="list-style-type: none"> The line to be monitored is selected with two Display Control switches. (See paragraph 9.3)
MDT (Button)	Triggers a Standard Loop Test or MDT Mechanized Drop Test on any of the 24 POTS lines. <ul style="list-style-type: none"> The type of test to be run is predetermined, based on the provisioned settings made by the craft person, on the CarrierNode Module prior to installation. The line to be tested is selected using the Display Controls prior to locally initiating a test. (See para. 9.2) The results of the test are automatically displayed in the Alpha-Numeric Display. When this test is run locally, results are only displayed locally (not at the switch or test controller).
Display Controls	Back - Fwd <ul style="list-style-type: none"> Menu control switch for the Alpha-Numeric Display Three position switch spring loaded to center position. Scrolls the display menu "Back" and "Forward" through a single layer in the menu structure. (See para. 9.1.2)
	Reset - Select * <ul style="list-style-type: none"> Menu control switch for the Alpha-Numeric Display Three position switch spring loaded to center position. Moves to deeper ("Select*") into the next layer in the display menu structure, or returns upward ("Reset") through the menu layers to the start position. (See paragraph 9)
Craft Access	DB-9 connection to CarrierNode for local (craft) access to GoDigital PC-based Adv. Diag. System software tool.

Installation Note

CN MOD 3X8P SELV 544 INT, XCel-8 CarrierNode Module



9. Alpha-Numeric LED Display, Messaging and Menu Navigation

9.1 DISPLAY SUMMARY Card and Basic Menu Navigation

Figure 9.1-1:
DISPLAY SUMMARY Card

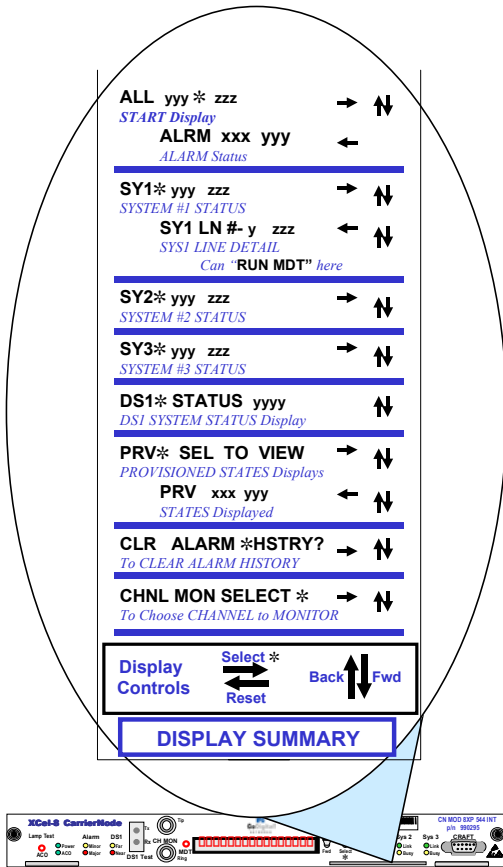

9.1.1 The CarrierNode Display Summary Card is a small plastic pull-out card that outlines the top menu level (only) for navigating the Alpha-Numeric Display. See **Figure 9.1-1**.

9.1.2 Menu Layers

There are eight (8) top level menu items (which are identified on the Display Summary Card). Most of these menu items provide access to additional levels of detail.

Table 9.1-1: Menu Top Level layers

Top Level	Second / Additional Levels
ALL yyy* zzz ↕ (Start Display) →	Select* goes to next level and locates any active alarms states.
SY1* __ _yyy* _zzz → ↕	Select* goes to System N (=1, 2 or 3) Status Detail <ul style="list-style-type: none"> If link is dropped, shows which span and # of drops since alarms were last cleared.
SY2* __ _yyy* _zzz → ↕	<ul style="list-style-type: none"> Checks status of each line on the System and indicates ON HOOK, BUSY, or RINGING
SY3* __ _yyy* _zzz → ↕	<ul style="list-style-type: none"> Chooses a line for running a loop/drop test.
DS1*STATUS yyyy → ↕	Select* goes to DS1 System Status Detail
PRV*SEL TO VIEW → ↕	Select* goes to List of provisioned settings
CLR ALARM*HSTRY → ↕	Select* will Clear the Alarm History
CHNL MON SELECT * → ↕	Select* will Choose one specific channel (#1 to 24) for monitoring at the front panel

Figure 9.1-1: Alpha-Numeric LED Display and Controls

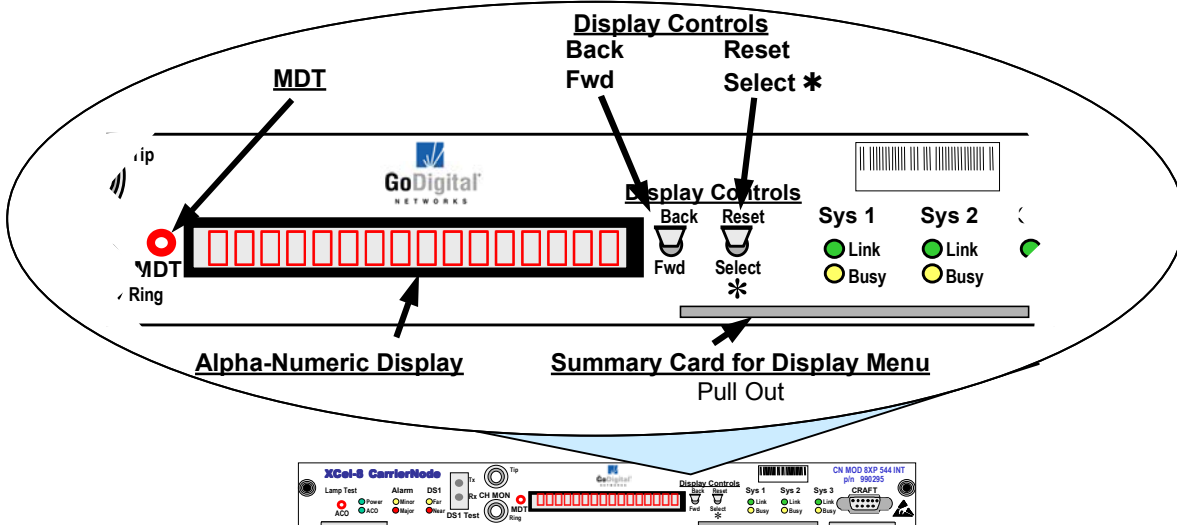

9.1.3 Navigating the Menus with the Display Controls

All menu navigation is accomplished with the two spring loaded Display Control Switches. The following detail the specific Display Control Instructions using these switches.

- **An asterisk “*”**

This character in any display, indicates that additional layers of information are available.

Toggling the right hand switch DOWN once, to the “Select *” position accesses this next (additional or more detailed) layer in the menu.

- **“Select *”**

Toggling the right hand switch DOWN to this position sends the menu and display to the NEXT LAYER in the menu. If no additional layers are available, then toggling to the “Select *” position will initiate no action.

In the various navigating tables this coincides with an arrow to the right, “→”.

- **“Reset”**

Toggling the right hand switch UP to this position

ALWAYS returns the menu to the ALL Display, or starting position in the first layer.

In the various navigating tables this coincides with an arrow to the left, “←”.

Note: This feature (returning or resetting to the starting position) keeps a craft person oriented to the top level or layer of menus.

- **“Fwd”**

Toggling the left hand switch DOWN to this position sends the menu and display to the next display in the CURRENT LAYER.

In the various navigating tables this coincides with an arrow to pointing down, “↓”.

- **“Back”**

Toggling the left hand switch UP to this position sends the menu and display to the previous display in the CURRENT LAYER.

ALWAYS returns the menu to the ALL Display, or starting position in the first layer.

In the various navigating tables this coincides with an arrow to pointing up, “↑”.

9.2 Loop / Drop Testing Using the MDT Button.

CarrierNode enables a local craft person to run a Standard Loop Test or MDT Mechanized Drop Test on any of the 24 POTS lines served by CarrierNode. No special tools are required, and the test is run by selecting the line to test and pressing the MDT button. See **Table 9.3-1, Block 2** and also **Table 9.3-2**.

9.2.1 Highlights of Local Loop / Drop (MDT) Testing

- The type of test to be run is predetermined, based on the provisioned settings made by the craft person, on the CarrierNode Module prior to installation
- The line to be tested is selected using the Display Controls prior to locally initiating a test.
- The results of the test are automatically displayed in the Alpha-Numeric Display.
- When this test is run locally, results are only displayed locally and are not reported at the switch or via the By-pass pair to a test controller.
- Running this test locally does not affect the ability of a test to be run normally from a central office or maintenance center.

9.2.2 Selecting a Line for Loop / Drop (MDT) Testing

The line to be tested is selected using the Display Controls to Select the System (#1, 2 or 3) and Line (#1 - #8) to be tested.

9.2.3 Running the Loop / Drop (MDT) Test

Once the line has been selected, press the MDT button once. The test will be run automatically and the results displayed on the Alpha-Numeric Display.

9.3 Display and Menu Detail

9.3.1 **Table 9.3-1** on the following pages provides detail on the menus, control switch inputs from the front panel, and the output messages for the XCel-8 CarrierNode Module.

Installation Note

CN MOD 3X8P SELV 544 INT, XCel-8 CarrierNode Module



Table 9.3-1: Display and Menu Detail

1	Step 1 is the "START" Display, and the "Reset" button and display time-outs ALWAYS returns to this display.				
	1-1	ALL_OK_NO_ALRMS	All systems are operating and no alarms currently being reported. No additional detail.		
	1-2	ALL_MJ_ON* MN_ON	The MAJOR Alarm in ON. The MINOR Alarm is ON. See additional detail.		
	Select* goes to one of these →	1-2.1	ALL_MJR_SY1	Indicates that CarrierNode is in a MAJOR Alarm State And Identifies the System or Systems that have dropped link and are in an Alarm Condition. Go back to the top layer and check each System Status	
		1-2.2	ALL_MJR_SY_2		
		1-2.3	ALL_MJR_SY_3		
		1-2.4	ALL_MJR_SY1_2		
		1-2.5	ALL_MJR_SY_2_3		
		1-2.6	ALL_MJR_SY1_3		
		1-2.7	ALL_MJR_CK_DS1		Go back to the top layer and check the DS1 Status
	1-2.8	ALL_MJR_BATT_FL	Check the battery voltage and -48Vdc power supply		
	1-3	ALL_MJ_ON* MN_OFF	The MAJOR Alarm in ON. The MINOR Alarm is OFF. See additional detail.		
		Select* goes to →	Same as Select for 1-2, above.		
	1-4	AL_MJ_OFF* MN_ON	The MAJOR Alarm in OFF. The MINOR Alarm is ON. See additional detail.		
	Fwd goes to 2 ↓	Select* goes to one of these →	1-4.1	ALL_MNR_SY1	Indicates that CarrierNode's MAJOR Alarm Thresholds have not been surpassed, but CarrierNode is in a MINOR Alarm State, And Identifies the System or Systems that have dropped link and are in an Alarm Condition. Go back to the top layer and check each System Status
1-4.2			ALL_MNR_SY_2		
1-4.3			ALL_MNR_SY_3		
1-4.4			ALL_MNR_SY1_2		
1-4.5			ALL_MNR_SY_2_3		
1-4.6			ALL_MNR_SY1_3		
1-4.7			ALL_MNR_CK_DS1	Go back to the top layer and check the DS1 Status	
2	Top Level for System 1 Status Display will show one of the below (2-1 through 2-8) based on current loop status				
	2-1	SY1*LINKED_xE_OK	System #1 is linked with "x" smart elements and no drops reported		
	Select* goes to →	2-1.0	SY1_DR_SP_y_DR_z	Sys. #1 is linked and not in an alarm state, but since alarms last cleared, Span "x" has dropped "z" times	
		2-1.1.1	SY1_LN_1_ON_HOOK	System #1, Line #1 is either	While in any of these line displays, press the MDT button. SY1_LN_x_MDT_TST will be displayed for one to two seconds while the test is run on Line "x". Results will be displayed for two (2) seconds. See Table 9.3-2 for descriptions of Loop/Drop Test results.
			or _RINGING	On Hook,	
			or _BUSY	Ringing or Busy	
		Fwd goes to next line ↓			
		2-1.2.1-3	SY1_LN_2_XXXXXXX	↓ Same for System #1, Line #2	
		2-1.3.1-3	SY1_LN_3_XXXXXXX	↓ Same for System #1, Line #3	
		2-1.4.1-3	SY1_LN_4_XXXXXXX	↓ Same for System #1, Line #4	
		2-1.5.1-3	SY1_LN_5_XXXXXXX	↓ Same for System #1, Line #5	
		2-1.6.1-3	SY1_LN_6_XXXXXXX	↓ Same for System #1, Line #6	
	2-1.7.1-3	SY1_LN_7_XXXXXXX	↓ Same for System #1, Line #7		
	2-1.8.1-3	SY1_LN_8_XXXXXXX	↓ Same for System #1, Line #8		
	Fwd goes to 2-1.0 above				
2-2	SY1*LINKED_xE_DR	System #1 is linked with "x" smart elements and no drops reported one or more dropped links since the alarms were last cleared.			
	Select* goes to →	Same as 2-1.0 through 2-1.8 above Sys. #1 is linked and not alarm state, but since alarms were last cleared, Span "x" has dropped "z" times			
2-3	SY1_MN_SP_X_DR_Y	XCel System #1 is in MINOR alarm state. Span linked once but has now dropped link. In System #1, Span # X has dropped link "Y" times.			
2-4	SY1_RT_DETECTION	XCel System #1 is in looking for an RT to link with. Normal and temporary linking indication.			
2-5	SY1_LINKING_WAIT	XCel System #1 is in trying to link with the 1st element. Normal & temporary linking indication.			
2-6	SY1_____NO_RT	XCel System #1 is in trying to link with the first element.			
		<ul style="list-style-type: none"> System #1 does not detect the presence of any "smart" elements. Reported when System #1 <u>does see</u> either an STR, or STRM, but <u>does not detect a "smart" element</u> in the loop. <i>Note: A "smart" element is an RTU, ADR, TAD or STR LP.</i> 			
Fwd goes to 3 ↓	2-7	SY1_SHORT_PWR_DWN	XCel System #1 has detected a SHORT in the DSL line. <ul style="list-style-type: none"> System #1 has powered down for approx. 1 minute, and will attempt re-linking for approximately 7 seconds. This process will be repeated every minute. 		
		SY1_OPEN_PWR_DWN	XCel System #1 has detected an OPEN in the DSL line. <ul style="list-style-type: none"> System #1 has powered down for approx. 1 minute, and will attempt re-linking for approximately 4 minutes. 		

Table 9.3-1: Display and Menu Detail
(Continued)

3	Fwd	SY2*_xxxxxx_yy_zz	Top Level for System 2 Status Display . <i>SAME sequences as System 1.</i>	
	goes to 4 ↓			
4	Fwd	SY3*_xxxxxx_yy_zz	Top Level for System 3 Status Display . <i>SAME sequences as System 1.</i>	
	goes to 5 ↓			
5	5-1	DS1*STATUS_ALARM	The DS1 is triggering one or more alarms.	
	Select*		5-1.1-1	DS1_NEAR __ MJ_ON NEAR end DS1 Alarm, is in a MAJOR alarm
	goes to	5.1.1	5-1.1-2	DS1_NEAR __ MN_ON NEAR end DS1 Alarm, is in a MINOR alarm
	→ Fwd goes to ↓		5-1.1-3	DS1_NEAR __ __ OK The DS1 is not in a NEAR end alarm state
		5.1.2	5-1.2-1	DS1_FAR __ __ MN_ON NEAR end DS1 Alarm, is in a MAJOR alarm
			5-1.2-2	DS1_FAR __ __ __ OK NEAR end DS1 Alarm, is in a MINOR alarm
Fwd	5-2	DS1*STATUS __ __ OK	There are no DS1 alarms	
goes to 6 ↓	Select*	Same as 5-1.1 above to check for DS1 NEAR and DS1 FAR alarm status detail.		
	goes to →			
6	PRV*_SEL_TO_VIEW	Top Level to start viewing the provisioning settings on the CarrierNode Module.		
	Select*	6.1	6.1-1	PRV_SY1_PWR __xxxV System #1 (Loop #1) is provisioned for xxx= "190" or "130" Vdc line powering.
	goes to → Fwd goes to ↓			
		6.2	6.2-1	PRV_SY2_PWR __xxxV System #2 (Loop #2) is provisioned for xxx= "190" or "130" Vdc line powering.
	Fwd goes to ↓			
		6.3	6.3-1	PRV_SY3_PWR __xxxV System #3 (Loop #3) is provisioned for xxx= "190" or "130" Vdc line powering.
	Fwd goes to ↓			
		6.4	6.4-1	PRV_DS-1 __ TR-008 or Provisioned for TR-008 DS1 format.
	Fwd goes to ↓		6.4-2	PRV_DS-1 __ xxxxxx Provisioned for xxxxxx.
			6.5-1	PRV_MJR1 __ __ 1_DSL or One or more DSL alarms will trigger a MAJOR
		6.5	6.5-2	PRV_MJR1 __ __ 2_DSL or Two or more DSL alarms will trigger a MAJOR
	Fwd goes to ↓		6.5-3	PRV_MJR1 __ __ 3_DSL or Three DSL alarms will trigger a MAJOR alarm
			6.5-4	PRV_MJR1 __ __ 0_DSL DSL alarms will not trigger a MAJOR alarm
		6.6	6.6-1	PRV_MJR2 __ __ NEAR or A DS1 NEAR alarm will trigger a MAJOR
	Fwd goes to ↓		6.6-2	PRV_MJR2 __ __ __ OFF NEAR alarm will not trigger a MAJOR alarm
			6.7-1	PRV_TEST __ 4TEL_LP or Std Loop Test only with 4Tel signatures
		6.7	6.7-2	PRV_TEST __ __ MLT_LP or Std Loop Test only with MLT signatures
	Fwd goes to ↓		6.7-3	PRV_TEST __ M9_MDT9 or Loop & Drop Test (MDT) with GR-909 signatures
			6.7-4	PRV_TEST __ M9_MDT3 Loop & Drop Test (MDT) with TR-398 signatures
		6.8	6.8-1	PRV_REM __ CH24_ON or Internal DS0 #24 provisioned for dial-up modem.
	Fwd goes to ↓		6.8-2	PRV_REM __ BYPP_ON External By-pass pair assigned for dial-up modem.
		6.9	6.9-1	PRV_REM_ACC_CH24 or Modem access for Advanced Diagnostics is DS0 #24 and not the rear panel modem pair.
	Fwd goes to ↓		6.9-2	PRV_REM_ACC_REAR Modem access for Advanced Diagnostics is the rear panel modem pair and not DS0#24
		6.10	6.10.-1	PRV_VER __ APPL x . x_ Application Software Version "x . x" of the CarrierNode Module
	Fwd goes to ↓			
		6.11	6.11-1	PRV_VER __ FPGA y . y_ FPGA Software Version "y . y" of the CarrierNode Module
	Fwd goes to ↓			
		6.12	6.12-1	PRV_VER __ PCBA_z __ PC Board Hardware Version "z" of the CarrierNode Module
Fwd	goes to 7 ↓			

Installation Note

CN MOD 3X8P SELV 544 INT, XCel-8 CarrierNode Module



Table 9.3-1: Display and Menu Detail
(Continued)

7	7-1	CLR_ALARM_CLEAR	There are no alarms in the history memory to be cleared
Fwd goes to 8 ↓	7-2	CLR_ALARM*HSTRY?	There are dropped links stored in memory. Toggling the "Select*" switch will: Clear all alarm histories for drop links on the individual Systems and spans, and Enable the Systems to restart their dropped link counts.
		Select* goes to 7-1	
8	8-1	CHNL_MON_SELECT*	No POTS channel is currently assigned to the Channel Monitor port.
	8-2	CHNL_BYP_CHL_xx* - FLASHING - Select* goes to → 8.2.1	Channel xx is currently in ACTIVE Channel Monitoring and assigned to the channel monitor port. Service to the subscriber on this line is temporarily interrupted. NOTE: When using the local Channel Monitoring capability the remote modem access is temporarily disabled.
Select* goes to →	8.1-1	MON_01_*SYS1 - CH01_ This is PASSIVE Channel Monitoring Select* goes to → Fwd goes to ↓	<p>(This is the same as 8.2 above)</p> <p>8.2 CHNL_BYP_CHL_01* - FLASHING - This is ACTIVE Channel Monitoring</p> <p>DS0 is by-passed at the CarrierNode and routed to the Channel Monitor port. See note below.</p> <p style="text-align: center;">Select* goes to →</p> <p>8.2.1 CHNL_MON_CLEARED - FLASHING -</p> <p>This display will flash while the by-pass is being reset for service to the subscriber.</p> <p>Display flashes for 2-3 seconds, then the display returns to 8-1.</p>
	8.1-2	MON_02_*SYS1 - CH02 ↓ →*	
	8.1-3	MON_03_*SYS1 - CH03 ↓ →*	
	8.1-4	MON_04_*SYS1 - CH04 ↓ →*	
	8.1-5	MON_05_*SYS1 - CH05 ↓ →*	
	8.1-6	MON_06_*SYS1 - CH06 ↓ →*	
	8.1-7	MON_07_*SYS1 - CH07 ↓ →*	
	8.1-8	MON_08_*SYS1 - CH08 ↓ →*	
	8.1-9	MON_09_*SYS2 - CH01 ↓ →*	
	8.1-10	MON_10_*SYS2 - CH02 ↓ →*	
	8.1-11	MON_11_*SYS2 - CH03 ↓ →*	
	8.1-12	MON_12_*SYS2 - CH04 ↓ →*	
	8.1-13	MON_13_*SYS2 - CH05 ↓ →*	
	8.1-14	MON_14_*SYS2 - CH06 ↓ →*	
	8.1-15	MON_15_*SYS2 - CH07 ↓ →*	
	8.1-16	MON_16_*SYS2 - CH08 ↓ →*	
	8.1-17	MON_17_*SYS1 - CH01 ↓ →*	
	8.1-18	MON_18_*SYS1 - CH02 ↓ →*	
	8.1-19	MON_19_*SYS1 - CH03 ↓ →*	
	8.1-20	MON_20_*SYS1 - CH04 ↓ →*	
	8.1-21	MON_21_*SYS1 - CH05 ↓ →*	
	8.1-22	MON_22_*SYS1 - CH06 ↓ →*	
	8.1-23	MON_23_*SYS1 - CH07 ↓ →*	
	8.1-24	MON_24_*SYS1 - CH08 ↓ →*	
Fwd goes back to 1 (Sart) ↓			<p>Back goes to ↑ 7 above</p> <p>Fwd goes to ↓ 1 Start</p> <p>Note: Service is interrupted to the subscriber, and the Channel Monitor port is delivered dial tone from the selected DS0.</p> <p>Active Channel Monitoring will TIME-OUT after approximately five (5) minutes and return service to the subscriber line.</p>

Table 9.3-2: Display Sequence and Result Messages when Running Local Loop / Drop Test

<p>MDT 1 SY1_LN_x_MDT_TST After testing is complete ↓ Results are Automatically reported → After 2-5 seconds the display returns to the line display SY1_LN_x_--</p>	<p>The MDT test on System #1 Line #x is being run and the results will automatically be reported. The test will take 1 – 2 seconds to complete. After the test is complete, the test results will be displayed for approximately two to five (2 – 5) seconds. After 2-5 seconds, the Diagnostic Display will clear the MDT results and will return to show the System # and Line # status.</p>
<p>MDT 1.1 SY1_LN_x_M_CTUF</p>	<p>XCel System: “CTU FAIL”. “CTU” circuit in the CarrierNode Is testing bad. Dispatch to the CarrierNode site for maintenance.</p>
<p>MDT 1.2 SY1_LN_x_M_DSLF</p>	<p>XCel System: “Bad DSL or RTU” “DSL” or RTU has failed. Trouble may be cable or electronics.</p>
<p>MDT 1.3 SY1_LN_x_M_RTUF</p>	<p>XCel System (*M9 ONLY): “Bad RTU”. The “RTU” functioning but is indicating a problem. Dispatch to the outside plant remote unit (RTU, ADR etc).</p>
<p>MDT 1.4 SY1_LN_x_M_HAZP</p>	<p>XCel System (*M9 ONLY): HAZARDOUS POTENTIAL Problem on Drop: T-G or R-G, AC voltage is greater than 50 volts rmsm or the T-G or R-G dc voltage is greater than 135 V. Dispatch to the drop site for maintenance.</p>
<p>MDT 1.5 SY1_LN_x_M_FEMF</p>	<p>XCel System (*M9 ONLY): “Foreign Electro-Motive Force” Problem on Drop: T-G or R-G, voltage is greater than 10 (rms) volts or the T-G or R-G dc voltage is greater than 6 volts (±6 V.) Dispatch to the drop site for maintenance.</p>
<p>MDT 1.6 SY1_LN_x_M_RESF</p>	<p>XCel System (*M9 ONLY): “Resistive Fault” Problem on Drop: T-G, R-G or T-R dc res. is less than 150 kΩ. Dispatch to the drop site for maintenance.</p>
<p>MDT 1.7 SY1_LN_x_M_ROH_</p>	<p>XCel System (*M9 ONLY): “Receiver-Off-Hook Test”. Indication based on criteria that discriminate between a resistive fault and a receiver-off-hook condition.</p>
<p>MDT 1.8 SY1_LN_x_M_RNGR</p>	<p>XCel System (*M9 ONLY): “Ringers Test”. Indication when the equivalent ringer load on the drop across tip and ring is less than 0.175 REN or greater than 5 REN.</p>
<p>MDT 1.9 SY1_LN_x_ _M_OK</p>	<p>XCel System: “ALL OK”</p>

10. Troubleshooting

NOTE: Detailed troubleshooting procedures are provided in the GoDigital System Practice, Document 010101 (Revision D or later) that is shipped with each CarrierNode Shelf.

10.1 When the CarrierNode Module is first plugged in, LED lamps illuminate briefly followed by blinking of the DSL and then the System Link LEDs for each loop until they are linked with an ADR, TAD or RTU even though they may have already linked with a Straight Through Repeater (STR) or Straight Through Repeater Module (STR MOD). This time can vary depending on the length of the loop, from 20 seconds to five minutes. If CarrierNode shows no LED indications, check the power connections to the shelf. If the shelf and installed cards are operating, return the card for repair.

10.2 Troubleshooting Highlights on Turn-up

10.2.1 If CarrierNode determines there is a shorted DSL it will stop powering that line immediately. This condition is indicated by a slow blink of the DSL lamp. Once every minute, CarrierNode will briefly power the DSL to determine if the shorted condition has been corrected. If so, CarrierNode will continue with the linking process.

10.2.2 Once the systems link, check for dial tone at the XCel field unit(s). If unable to draw dial tone: verify that a DS1 connection does exist to the switch and/or DLC from CarrierNode. Although the pair may be physically connected, the necessary translations may not be complete.

10.2.3 In new installations before the outside plant elements are installed the DSL LED lamp should blink two times per second as CarrierNode attempts to link.

NOTE: All XCel field units have a blinking LED indicator to show that it is being powered, and glows steadily when linked.

10.2.4 If the outside plant elements are installed and no DSL link can be established, there is either a loading coil in the loop or the DSL loop limits have been exceeded. If the pair assigned is thought to be non-loaded, then a check for an unknown load coil is highly recommended.

Installation Note

CN MOD 3X8P SELV 544 INT, XCel-8 CarrierNode Module



NOTE: If an XCel-8 System's DSL connection is reversed (T-R), similar LED indicators will result. A load coil does not prevent line powering, but does block the 136 kHz digital signal from the RTU.

10.2.5 When CarrierNode initially links with an entire loop, it 'inventories' all "smart" elements. If any cable section is cut, or if any OSP element fails the MINOR LED lamp will illuminate. The loop can be examined using either the toggle switches and alpha-numeric display, or by using the GoDigital PC-based Advanced Diagnostic System craft interface tool (available separately from GoDigital).

11. Detailed CarrierNode Provisioning Switch Setting Options

11.1 Switch SW1 Setting Detail: DS1 / DSX-1 Options

Table 11-1 DS1 Option Settings – ALL on SWITCH SW1

Function	Option	Board SW #	Switch Position	Comment	
Framing	SF (D4) (Superframe) ●	SW1-1	OFF ●	● Factory Default ●	
	ESF (Ext. Superframe)		ON		
SLC 96 Mode	T1	SW1-2	OFF	Activates Switch SW1-1	
	TR-008 / SLC 96 ●		ON ●	● Factory Default ●	
GR-303 Mode	T1 ●	SW1-3	OFF ●	● Factory Default ●	
	GR-303		ON	Overrides SLC 96 Selection	
Coding	AMI ●	SW1-4	OFF ●	● Factory Default ●	
	B8ZS		ON		
LBO (Line Build Out)	Distance	Switch & Position			Comment
		SW1-5	SW1-6	SW1-7	
	0 dB & 0 - 133 ft DSX ●	OFF ●	OFF ●	OFF ●	● Factory Default ●
	133 - 266 ft DSX	OFF	OFF	ON	
	266 - 399 ft DSX	OFF	ON	OFF	
	399 - 533 ft DSX	OFF	ON	ON	
	533 - 655 ft DSX	ON	OFF	OFF	
	-7.5 dB	ON	OFF	ON	
-15 dB	ON	ON	OFF		
-22.5 dB	ON	ON	ON		
Function	Option	Board SW #	Switch Position	Comment	
Loop Back	Normal ●	SW1-8	OFF ●	● Factory Default ●	
	T1 Loopback		ON	Payload Loop Back	

11.2 Switch SW2 Setting Detail: TIMING Options

Table 11-2 TIMING Option Setting Detail – ALL on SWITCH SW2

Function	Option	Board SW #	Switch Position	Comment
Timing	Loop Timed ●	SW2-1	OFF ●	● Factory Default ● T1 & FPGA recovery.
	Internal Timed		ON	
In-Band Loop Detect	Loop Detect Disabled ●	SW2-2	OFF ●	● Factory Default ● Enables or Disables the detection of loop up / or loop down codes
	Loop Detect Enabled		ON	
None	Mfg. Testing Only ●	SW2-3	OFF ●	● Factory Default ● No options available
FDL Loop Detect (ESF only)	Disabled ●	SW2-4	OFF ●	● Factory Default ●
	Enabled ●		ON	
None	No option ●	SW2-5	OFF ●	● Factory Default ● Switches SW2-5 through SW2-8 are NOT currently used by CarrierNode
	No option ●	SW2-6	OFF ●	
	No option ●	SW2-7	OFF ●	
	No option ●	SW2-8	OFF ●	

11.3 Switch SW3 Setting Detail

11.3.1 ALARM THRESHOLD Options

The Factory Default (●) setting will report a MAJOR Alarm only when all three XCel-8 loops report a failure. This level is based on local practices used many past XCel System installations. This Threshold setting is solely up to customers and their local practice and will not affect CarrierNode normal operation.

Table 11-3A: ALARM THRESHOLD Option Settings Detail – ALL on SWITCH SW3

Function	Option	Switch & Position		Comment
		SW3-1	SW3-2	
Determines the number of DSL's in an Alarm Condition that trigger a MAJOR Alarm	DSL Alarms will NOT trigger a MAJOR Alarm	OFF	OFF	Refers to CarrierNode's Contact Alarms: MAJOR – VISUAL & MAJOR – AUDIBLE <i>Note: CarrierNode does not activate the DSL Alarm tracking on a System or loop until it has linked at least once since last "Alarm Clear" or CarrierNode Module power cycle.</i> ● Factory Default ●
	Two or More DSL Alarms trigger a MAJOR Alarm	OFF	ON	
	One or More DSL Alarms trigger a MAJOR Alarm	ON	OFF	
	Three DSL Alarms trigger a MAJOR Alarm ●	ON ●	ON ●	

11.3.2 T1 ALARM Reporting Options

The Factory Default (●) setting does NOT report a CarrierNode MAJOR Alarm when the T1 Near End Alarm is triggered. Only a CarrierNode MINOR Alarm is activated. Normally the upstream DS1 transmission equipment will be relied upon to report the DS1 alarming status. This setting is solely up to customers and their local practice and will not affect CarrierNode normal operation.

Table 11-3B: T1 ALARM Reporting Option Settings Detail – on SWITCH SW3

Function	Option	Board SW #	Switch Position	Comment
T1 Near End Alarm to be Reported as MAJOR Alarm by CarrierNode	T1 Near End Alarm does NOT trigger CN MAJOR Alarm ●	SW3-3	OFF ●	● Factory Default ● Refers to CarrierNode's Contact Alarms: MAJOR – VISUAL & MAJOR - AUDIBLE
	T1 Near End Alarm triggers a CN MAJOR Alarm		ON	

11.3.3 MODEM ACCESS Line Options

Modem access is used to support dial-up remote access to the CarrierNode Shelf for connection to GoDigital's PC-based Advanced Diagnostic System.

NOTE: These options do NOT influence local craft access to the CarrierNode with a direct DB-9 connection from a PC. A craft person with access directly to the front of the CarrierNode Module has priority over dial-up access regardless of the path of this setting.

11.3.3.1 CarrierNode has the option of receiving the modem line either on a dedicated (separate) copper pair connected to the rear of the shelf via wire-wrap pins. This option requires a separate line/pair be connected to CarrierNode.

11.3.3.2 Alternatively, the engineer can commit one of the DS0s in the T1 (DS0 #24) for the sole use of providing dial-up modem access.

CAUTION: Using this option (T1 DS0 #24) precludes the use of this DS0 for POTS service delivery. In this case the third XCel-8 System (System #3) being served by the XCel-8 CarrierNode Module will only have seven POTS lines available for delivery to subscribers. These lines will be lines #1 through #7.

XCel-8 CarrierNode does not provide any capability to select which System or which line is consumed when using the T1 DSO for modem access.

Installation Note

CN MOD 3X8P SELV 544 INT, XCel-8 CarrierNode Module



Table 11-3C: MODEM ACCESS Line Option Setting Detail
– on SWITCH SW3

Function	Option	Board SW #	Switch Position	Comment
Determines how the GoDigital Advanced Diagnostic System will remotely access the CarrierNode Shelf. Either: <ul style="list-style-type: none"> • a <u>separate pair</u> is used for modem access to the Shelf or • <u>DS0 #24 is dedicated</u> (in the DS1) for modem access. 	Rear Panel Modem Access ●	SW3-4	OFF ●	<ul style="list-style-type: none"> • Factory Default Dedicated line and copper pair is needed / used to CarrierNode Shelf for dial up modem access.
	T1 Channel (DS0 #24) Modem Access		ON	<ul style="list-style-type: none"> • T1 Channel 24 in the upstream link is committed to a dial-up modem in CarrierNode. • XCel-8 System #3 will only have seven lines available for delivery.

11.3.4 SW3-5, SW3-6, SW3-7 and SW3-8 are UNUSED

These switches are not currently used by the XCel-8 CarrierNode and should in the OFF position.

11.4 Switches SW4, SW5, SW6 and SW7 Settings Detail: LOOP/DROP TEST and SIGNATURE Options

Table 11-4: LOOP/DROP TEST and SIGNATURE Option Settings Detail
– on SWITCHES SW4, SW5, SW6 and SW7

Loop/ Drop Test Options	CN Board Switch Module #	Switch Number "N" (SWx-N)												Comments
		-1	-2	-3	-4	-5	-6	-7	-8	-9	-10	-11	-12	
<ul style="list-style-type: none"> • Standard Loop Test with • 4TEL Signatures 	SW4-N	All ON								n/a	n/a	n/a	n/a	<ul style="list-style-type: none"> • Independant Telcos - Most • Verizon - West
	SW5-N	All OFF ●								n/a	n/a	n/a	n/a	
	SW6-N	All OFF												
	SW7-N	All OFF ●												
<ul style="list-style-type: none"> • Standard Loop Test with • MLT Signatures 	SW4-N	All OFF ●								n/a	n/a	n/a	n/a	<ul style="list-style-type: none"> • Some Qwest early applications (without MDT)
	SW5-N	All ON								n/a	n/a	n/a	n/a	
	SW6-N	All OFF												
	SW7-N	All OFF ●												
<ul style="list-style-type: none"> • Mechanized Loop & Drop Test (MDT) with • GR-909 Signatures 	SW4-N	All OFF ●								n/a	n/a	n/a	n/a	<ul style="list-style-type: none"> • Factory Default • Qwest • BellSouth • SBC
	SW5-N	All OFF ●								n/a	n/a	n/a	n/a	
	SW6-N	All ON ●												
	SW7-N	All OFF ●												
<ul style="list-style-type: none"> • Mechanized Loop & Drop Test (MDT) with • TR-398 Signatures 	SW4-N	All OFF ●								n/a	n/a	n/a	n/a	<ul style="list-style-type: none"> • Verizon East ONLY
	SW5-N	All OFF ●								n/a	n/a	n/a	n/a	
	SW6-N	All OFF												
	SW7-N	All ON												

11.5 Switch SW8, SW9 and SW10 Setting Detail

11.5.1 DSL LINE POWERING Option Setting Detail

The XCel-8 CarrierNode has the ability to provide either ± 190 Vdc or ± 130 Vdc over the XCel-8 System loop pairs.

11.5.1.1 The voltage level is normally determined by local practice and standard procedures.

11.5.2 Each Loop is Separately Provisioned for DSL Line Powering Voltage

The XCel-8 CarrierNode has the ability to set the line power level for each of the three loops separately. They are not required to be the same.

11.5.2.1 Normally all loops are set for the line powering level that is standard at that telco.

11.5.2.2 If no local standards are set then GoDigital recommends setting all loops to ± 190 Vdc line power. Once the CarrierNode Module is installed, the line power setting can only be changed by removing the Module and changing the switches. This will cause a temporary drop of loops that were previously running.

11.5.3 The Factory Default (●)

Factory Default (●) settings supports ± 130 Vdc Line power on each DSL Pair. This default level was chosen because some customers have not approved the higher voltage level in their networks.

Table 11-5: DSL LINE POWERING Option Setting Detail
– On SWITCHES SW8, SW9 and SW10

Function	Option	Switch & Position			Comment
		SW8 for Loop/System #1	SW9 for Loop/System #2	SW10 for Loop/System #3	
Voltage For XCel-8 Line Powering	± 130 Vdc ●	130 ●	130 ●	130 ●	● <i>Factory Default</i> ●
	± 190 Vdc	190	190	190	

Installation Note

CN MOD 3X8P SELV 544 INT, XCel-8 CarrierNode Module



12. GoDigital APPROVED and NON-APPROVE Protector Types for CarrierNode

12.1 MDF Frame-Style Protectors

Table 12.1-1

APPROVED MDF-TYPE Protectors

MFG	PART #
Lucent	21NA98
Lucent	990H01
Northern Telecom	F03
Northern Telecom	11A1G0
Northern Telecom	M08C
OneAC	92S5
Porta Systems	4597M
Porta Systems	4797M
Reltec	6U2VS
Reltec	R3B3E
Reltec	R4B1E
Corning/Siecor	4B3ESC
Corning/Siecor	6SSH
Corning/Siecor	6ESH
Corning/Siecor	3010
Corning/Siecor	12A9KA
Corning/Siecor	12A9TA
Corning/Siecor	4110
Corning/Siecor	P2510
Corning/Siecor	P4210

Table 12.1-2

NON-APPROVED MDF-TYPE Protectors

MFG	PART #
Lucent	980H39
Lucent	990H02
Corning/Siecor	6SPE
Corning/Siecor	6SSE
Sylvania	5G-GT

12.2 Station-Type Protectors

Table 12.2-1

APPROVED Station-Type DSL Line Protectors

MFG	MODEL or PART #	Type
TII	AD-03-W-FS	Gel
Corning (Siecor)	SPD 127-XV-S	Gel
Other approved DSL replacement protectors		
Corning (Siecor)	356-XY	356

Table 12.2-2

NON-APPROVED Station-Type DSL Line Protectors

MFG	MODEL or PART #	Type
TYCO *	GSSP-0302-00-WO0B-A	Gel
TYCO	GSSP-0202-00-WO0B-A	Gel
TYCO	GSSP-0101-00-WO0B-A	Gel
TII	AD-M2-W-FS	Gel
TII	AD-02-W-FS	Gel
TII	AD-01-W-FS	Gel
TII	356M2	356
Corning (Siecor) *	356-SW	356

CONTACTING GODIGITAL

GoDigital Networks Corporation
41652 Boscell Road
Fremont, CA 94538

1-800-297-2424
1-510-979-2200
Fax 510-226-8785

Email

GoDigital Sales: sales@godigital.com
Technical Assistance: product.support@godigital.com